

STABILITY AND OPTIMAL CONTROL FOR SOME CLASSES OF TRITROPHIC SYSTEMS

LUCA GALBUSERA

previously at CNR

Institute of Applied Mathematics and Information Technology “Enrico Magenes”

Via E. Bassini 15, 20133 Milano, Italy

currently at European Commission, DG Joint Research Center (JRC)

Institute for the Protection and Security of the Citizen (IPSC)

Via E. Fermi 2749, 21027 Ispra (VA), Italy

SARA PASQUALI

CNR, Institute of Applied Mathematics and Information Technology “Enrico Magenes”

Via E. Bassini 15, 20133 Milano, Italy

GIANNI GILIOLI

Department of Molecular and Translational Medicine, University of Brescia

Viale Europa 11, 25125 Brescia, Italy

ABSTRACT. The objective of this paper is to study an optimal resource management problem for some classes of tritrophic systems composed by autotrophic resources (plants), bottom level consumers (herbivores) and top level consumers (humans). The first class of systems we discuss are linear chains, in which biomass flows from plants to herbivores, and from herbivores to humans. In the second class of systems humans are omnivorous and hence compete with herbivores for plant resources. Finally, in the third class of systems humans are omnivorous, but the plant resources are partitioned so that humans and herbivores do not compete for the same ones. The three trophic chains are expressed as Lotka-Volterra models, which seems to be a suitable choice in contexts where there is a shortage of food for the consumers. Our model parameters are taken from the literature on agro-pastoral systems in Sub-Saharan Africa.

1. Introduction. The scientific literature on natural resource exploitation is displaying a steady growth and a number of new research directions have been explored. One of the central topics to attract the interest of the community is represented today by the analysis of the qualities and effects of human interactions with the environment, which requires to be adequately modeled in many different practical contexts [23] considering its fundamental implications on ecosystem balancing, social welfare and economic growth [3]. Trophic systems that include humans were classified in [11] as a relevant category of ecosystems from the management viewpoint and experiments have been conducted to characterize the ecological role of humans in specific biological communities [4]. The impact of human development on sustainability is also a central topic in ecological economics studies [28].

2010 *Mathematics Subject Classification.* Primary: 37N35, 49-XX, 93D20; Secondary: 92Bxx.
Key words and phrases. Trophic system, Lotka-Volterra, coexistence, extinction, stability, optimal control.

In recent times, control theory has been used to support resource management decisions. Relevant examples include harvesting [21, 39], fishery management [5, 30, 8], pest control [6, 31]. In many of the references reported above, the reader can observe a trend towards the synthesis of optimal resource exploitation strategies. In particular, a number of papers have considered how optimal control theory can be used to manage trophic chains. For instance, in [22] the optimal harvesting strategy of a single growing species was addressed. In [32], an infinite-horizon optimal control problem with discount was proposed, consisting in the maximization of a combination between the human population level and the associated welfare status over time. In [10], optimal control theory was applied to stabilization and synchronization problems in Lotka-Volterra models. Optimal foraging was discussed in [19] within the context of two-prey-one-predator populations showing adaptive behaviors. Optimization methods for solving optimal control problems involving Lotka-Volterra models were investigated in [35] under special restrictions on the time dependent control functions. In [1] the problem of maximizing the total population in a Lotka-Volterra tritrophic system was studied and the optimal species separation was characterized in terms of the model parameters. In [36], optimal control was applied to a Rosenzweig-MacArthur tritrophic system in order to achieve sustainable management strategies. These results were extended to stochastic systems in [37]. Reference [2] deals with the optimal management of two species accounting for various types of functional responses describing predator-prey interactions.

In this paper we consider how optimal resource management policies depend on special structures of the trophic chain and investigate infinite time horizon optimal control problems with the objective of characterizing management strategies that sustain the human population's biomass and promote welfare. In particular,

- we consider a fully tritrophic system composed by plants, herbivores and humans. The modeling of the plant resources accounts for the importance of the primary production for the sustainability of agro-pastoral systems in fragile ecosystems like most of the arid and semi-arid areas where pastoralism in Africa is present;
- moreover, the diversity of the trophic structure characterizing the agro-pastoral transition is analyzed. According to [7], in the household economy of the traditional pastoral system humans act as secondary consumers and only a limited amount of energy comes from the plants. Under the effects of many ecological, economic and social drivers [9, 33] traditional agro-pastoral communities have changed their habits towards the sedentarization and the integration of smallholder farm systems into the grassland. The trophic chain sustaining these communities becomes more complex and diversified. Different management strategies of the grassland and cropping systems (e.g., pure pasture or mixed stands, choice of the level of exploitation) lead to different trophic structures of the ecological system supporting the agro-pastoral community and are expected to put in place different challenges to the sustainability of the agro-pastoral system. The analysis we perform deals with stability properties of these trophic chains and aims at the definition of sustainable level of exploitation of resources.

A representation of the system under analysis, which takes into account the trophic interactions between the resources and the human population together with its welfare status, is reported in Figure 1. Therein ξ_1 , ξ_2 , y , $z \geq 0$ are the biomasses of two plant sources, the herbivores and the human population, respectively, and

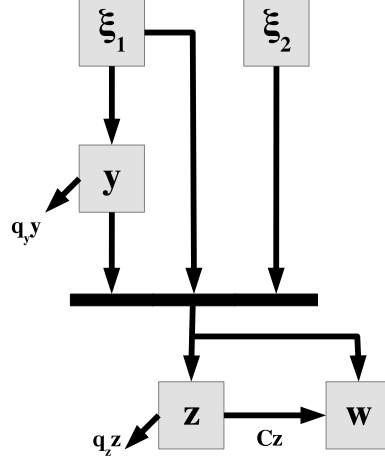

FIGURE 1. The model of the trophic chains under analysis including the welfare compartment; arrows represent biomass transfers.

$w \geq 0$ is a measure of the level of human welfare. Parameters $q_y, q_z > 0$ are the specific loss rates of organic matter due to excretion, death and respiration at the upper levels of the trophic chain, represented by herbivores and humans. Quantity $C \geq 0$ is a measure of the specific human biomass consumption rate for non-vital activities not directly related to trophic processes (e.g., adaptation and activities related to welfare). This graphical representation puts in evidence that a fraction of the human's harvest is devoted to increasing the biomass of the human population, while the rest is spent to improve the quality of life. Moreover, it is also assumed that a portion Cz of the human biomass is lost for non-vital activities, as well.

The main objective of this paper is to analyze this system taking into account different trophic relationships between humans and their resources, as it will be illustrated in the following. Thus, for plainness we will not include the level of welfare as a state variable characterizing the system, while a human biomass consumption that can be interpreted a support to non-vital activities is maintained in the balance equations, as proposed in [32, 14]. Following these references, the human benefit achieved through the consumption term Cz is expressed by a utility function $W(C)$, which is assumed to fulfill the following assumptions [32]

$$W'(C) > 0, W''(C) < 0, \lim_{C \rightarrow \infty} W(C) < \infty \quad (1)$$

with $(')$ and $('')$ denoting the first and second derivatives with respect to the argument. According to the latter simplifying assumption, a general structure for the different classes of tritrophic systems we will consider is provided by the following set of ODEs, representing two interacting subsystems $\tilde{\mathcal{S}}_1$ and $\tilde{\mathcal{S}}_2$:

$$\bar{\mathcal{S}}_1 : \begin{cases} \dot{\xi}_1 &= r_1 \xi_1 \left(1 - \frac{\xi_1}{K_1}\right) - \bar{D}_{y\xi_1} f_{y\xi_1} \left(\frac{\xi_1}{a_{y\xi_1}}\right) y - \bar{D}_{z\xi_1} f_{z\xi_1} \left(\frac{\xi_1}{a_{z\xi_1}}\right) z \\ \dot{y} &= y \left[\theta_{y\xi_1} \bar{D}_{y\xi_1} f_{y\xi_1} \left(\frac{\xi_1}{a_{y\xi_1}}\right) - q_y \right] - \bar{D}_{zy} f_{zy} \left(\frac{y}{a_{zy}}\right) z \\ \dot{z} &= z \left[\sum_{i=1,2} \theta_{z\xi_i} \bar{D}_{z\xi_i} f_{z\xi_i} \left(\frac{\xi_i}{a_{z\xi_i}}\right) + \theta_{zy} \bar{D}_{zy} f_{zy} \left(\frac{y}{a_{zy}}\right) - (q_z + C) \right] \end{cases} \quad (2)$$

$$\bar{\mathcal{S}}_2 : \begin{cases} \dot{\xi}_2 &= r_2 \xi_2 \left(1 - \frac{\xi_2}{K_2}\right) - \bar{D}_{z\xi_2} f_{z\xi_2} \left(\frac{\xi_2}{a_{z\xi_2}}\right) z \end{cases}$$

together with the initial condition

$$(\xi_1(0), y(0), z(0), \xi_2(0)) = (\xi_1^0, y^0, z^0, \xi_2^0)$$

Parameter r_i , for $i = 1, 2$, represents the specific growth rate of the i -th source and K_i is the carrying capacity. Trophic interactions are modeled by means of the functional response $f_{i_1 i_2}(s)$, for $(i_1, i_2) \in \{(y, \xi_1), (z, \xi_1), (z, y), (z, \xi_2)\}$, which is assumed to be concave and bounded ([41], p. 87). In the applications, Holling-type II or Ivlev models are commonly used [16, 15]. The corresponding terms $a_{i_1 i_2} > 0$ are related to the efficiency of the predation process. Parameters $\theta_{y\xi_1}, \theta_{z\xi_1}, \theta_{zy}, \theta_{z\xi_2} \in (0, 1]$ are the biomass conversion factors. Finally, the biomass flow across levels also depends on quantities $\bar{D}_{y\xi_1}, \bar{D}_{z\xi_1}, \bar{D}_{zy}$ and $\bar{D}_{z\xi_2}$, which describe the food demands of consumers per time unit. In general, we assume $\bar{D}_{y\xi_1} > 0$ and $\bar{D}_{z\xi_1}, \bar{D}_{zy}, \bar{D}_{z\xi_2} \geq 0$. From the structure of system $\bar{\mathcal{S}}_1$ in (2) it can be observed that various types of trophic chains can be accounted for, including cases in which humans act as omnivores. Furthermore, the presence of subsystem $\bar{\mathcal{S}}_2$ enables us to consider the effects of the availability of a complementary food source for the top level consumer. This aspect seems to be relevant both in a modeling perspective and for control purposes, as emphasized in the recent literature [38, 18, 25, 40, 26, 17].

The rest of this paper is organized as follows: in Section 2 we specify the Lotka-Volterra approximation of system (2), show positiveness and boundedness of the state trajectories, and identify a positively invariant and attractive set. In Section 3 we characterize the non-coexistence equilibrium states and in Section 4 the coexistence equilibrium states. In Section 5 we examine the stability of the coexistence equilibrium states. In Section 6 we present an optimal control problem and characterize some relevant associated properties. Section 7 contains some numerical examples.

2. Trophic chain models. We study a class of models obtained from (2) through a linear approximation of functions $f_{i_1 i_2}(\cdot)$:

$$\mathcal{S}_1 : \begin{cases} \dot{\xi}_1 &= \xi_1 \left[r_1 \left(1 - \frac{\xi_1}{K_1}\right) - D_{y\xi_1} y - D_{z\xi_1} z \right] \\ \dot{y} &= y \left[\theta_{y\xi_1} D_{y\xi_1} \xi_1 - q_y - D_{zy} z \right] \\ \dot{z} &= z \left[\theta_{z\xi_1} D_{z\xi_1} \xi_1 + \theta_{z\xi_2} D_{z\xi_2} \xi_2 + \theta_{zy} D_{zy} y - (q_z + C) \right] \end{cases} \quad (3)$$

$$\mathcal{S}_2 : \begin{cases} \dot{\xi}_2 &= \xi_2 \left[r_2 \left(1 - \frac{\xi_2}{K_2}\right) - D_{z\xi_2} z \right] \end{cases}$$

where

$$D_{i_1 i_2} = \bar{D}_{i_1 i_2} \frac{f'_{i_1 i_2}(0)}{a_{i_1 i_2}} \tag{4}$$

System (3) is a Lotka-Volterra model; the use of the approximation (4) is feasible when the biomass of the preyed species is very limited, as it is the case in the application we are addressing. In this paper, all parameters of model (3) will be assumed to be assigned constants with the notable exception of C , $D_{z\xi_1}$, D_{zy} and $D_{z\xi_2}$, which represent the set of control variables whose value along time has to be chosen in order to maximize an objective functional. As the discussion of our results on optimal control is postponed to Section 6, until then these quantities are assumed to be constant over time as well, in order to perform an analysis of the equilibrium states and the associated stability properties.

For future utility, introduce the following notation, with $i = 1, 2$:

$$g_{y\xi_1} = \frac{r_1}{D_{y\xi_1} K_1}, \quad g_{z\xi_i} = \frac{r_i}{D_{z\xi_i} K_i}$$

and

$$e_{y\xi_1} = \frac{q_y}{\theta_{y\xi_1} D_{y\xi_1} K_1}, \quad e_{z\xi_i} = \frac{q_z + C}{\theta_{z\xi_i} D_{z\xi_i} K_i}, \quad e_{zy} = \frac{q_z + C}{\theta_{zy} D_{zy} K_1}$$

It is assumed that these quantities are well defined each time they are used.

System (3) is a general representation capturing, as special cases, the three trophic chains we are interested in (see Figure 2), namely

1. *linear chain* (\mathcal{S}^l): we consider only subsystem \mathcal{S}_1 and assume $D_{z\xi_1}$, $D_{z\xi_2} = 0$ and $D_{zy} > 0$;
2. *food chain with omnivory* (\mathcal{S}^o): we consider only subsystem \mathcal{S}_1 and assume $D_{z\xi_2} = 0$, and $D_{z\xi_1}$, $D_{zy} > 0$;
3. *food chain with omnivory and source partition* (\mathcal{S}^p): we consider the composition of subsystems \mathcal{S}_1 and \mathcal{S}_2 and assume $D_{z\xi_1} = 0$ and D_{zy} , $D_{z\xi_2} > 0$.

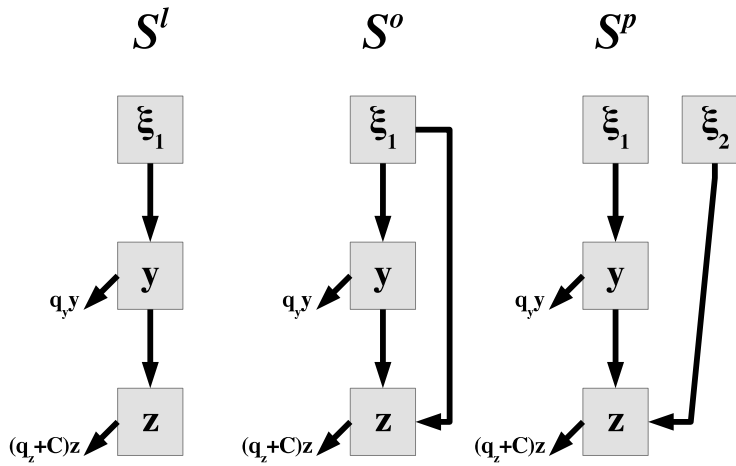

FIGURE 2. Types of trophic chains under analysis.

In our perspective, the different structures described above can serve as a simplified representation of different practical situations. In particular, the linear chain represents the humans as consumers of food drawn from an animal source; as such, it will be referred to as an approximate description of traditional pastoral systems. The other cases model humans as omnivores, and hence we refer to them as representations of an agro-pastoral system. In particular, in the case of \mathcal{S}^p a source partition is introduced in order to better model the situation in which herbivores and humans access separate vegetable food sources, i.e. forage and crops, respectively.

We now formulate a result about the boundedness of state trajectories in the positive cone and the existence of an attractive set, referring to system (3) in its general form:

Theorem 2.1. *Define the set*

$$\Omega = \left\{ (\xi_1, y, z, \xi_2) \in \mathbb{R}_0^{4+} : \right. \\ 0 \leq \xi_i \leq K_i, \quad i = 1, 2, \\ 0 \leq \xi_1 + \frac{y}{\theta_{y\xi_1}} \leq K_1 + \frac{r_1 K_1}{q_y 4} \\ 0 \leq \xi_1 + \frac{y}{\theta_{y\xi_1}} + \frac{z}{\theta_{y\xi_1} \theta_{zy}} + \frac{\theta_{z\xi_2} \xi_2}{\theta_{y\xi_1} \theta_{zy}} \leq \\ \left. K_1 + \frac{r_1 K_1}{q_y 4} + \frac{1}{q_z + C} \left(\frac{r_1 K_1}{4} + \frac{\theta_{z\xi_2} r_2 K_2}{\theta_{y\xi_1} \theta_{zy} 4} \right) + \frac{\theta_{z\xi_2}}{\theta_{y\xi_1} \theta_{zy}} K_2 \right\}$$

The following properties hold:

1. Ω is positively invariant for system (3);
2. $\forall (\xi_1^0, y^0, z^0, \xi_2^0) \in \mathbb{R}_0^{4+}$, $\lim_{t \rightarrow \infty} (\xi_1(t), y(t), z(t), \xi_2(t)) \in \Omega$.

Proof. See Appendix A. □

The notations introduced above and Theorem 2.1 are useful in defining parameter regimes with non-trivial dynamics. First recall that, from point 2 in Theorem 2.1, it results $\limsup_{t \rightarrow \infty} \xi_i(t) \leq K_i, i = 1, 2$. Consequently, since we are assuming that all the model parameters (including the controls) are constant over time, to avoid trivial dynamics starting from $(\xi_1^0, y^0, z^0, \xi_2^0) > 0$ we have to rule out the condition $\theta_{y\xi_1} D_{y\xi_1} K_1 - q_y < 0$, which would imply $\lim_{t \rightarrow \infty} y(t) = 0$ in view of the second equation in (3). This would also imply $\lim_{t \rightarrow \infty} z(t) = 0$ in the case of \mathcal{S}^l . Furthermore, if $\theta_{z\xi_1} D_{z\xi_1} K_1 - (q_z + C) < 0$ in \mathcal{S}^o and $\theta_{z\xi_2} D_{z\xi_2} K_2 - (q_z + C) < 0$ in \mathcal{S}^p , then $\lim_{t \rightarrow \infty} z(t) = 0$ also in these cases. In conclusion, from now on we make the following assumptions

$$\begin{cases} e_{y\xi_1} < 1, & \text{for } \mathcal{S}^l \\ e_{y\xi_1} < 1 \text{ and } e_{z\xi_1} < 1, & \text{for } \mathcal{S}^o \\ e_{y\xi_1} < 1 \text{ and } e_{z\xi_2} < 1, & \text{for } \mathcal{S}^p \end{cases} \quad (5)$$

which are necessary in order to avoid trivial dynamics, leading to $\lim_{t \rightarrow \infty} y(t) = 0$ and/or $\lim_{t \rightarrow \infty} z(t) = 0$.

The next three sections are devoted to the existence and stability analysis of the equilibrium states of system (3) in its special forms. The stability properties are determined by a local analysis based on the system's Jacobian, reported in Appendix B, as well as on Lyapunov functions, in some cases.

3. Non-coexistence equilibrium states and their stability. Non-coexistence equilibrium states of system (3) are defined as states where at least one species goes extinct. We now provide a list of the non-coexistence equilibrium states of systems \mathcal{S}^l , \mathcal{S}^o and \mathcal{S}^p :

1. **System \mathcal{S}^l**

$$\begin{aligned} E_0^l &= (0, 0, 0) \\ E_{\xi_1}^l &= (K_1, 0, 0) \\ E_{\xi_1 y}^l &= K_1 \left(e_{y\xi_1}, g_{y\xi_1}(1 - e_{y\xi_1}), 0 \right) \end{aligned}$$

2. **System \mathcal{S}^o**

$$\begin{aligned} E_0^o &= (0, 0, 0) \\ E_{\xi_1}^o &= (K_1, 0, 0) \\ E_{\xi_1 y}^o &= K_1 \left(e_{y\xi_1}, g_{y\xi_1}(1 - e_{y\xi_1}), 0 \right) \\ E_{\xi_1 z}^o &= K_1 \left(e_{z\xi_1}, 0, g_{z\xi_1}(1 - e_{z\xi_1}) \right) \end{aligned}$$

3. **System \mathcal{S}^p**

$$\begin{aligned} E_0^p &= (0, 0, 0, 0) \\ E_{\xi_1}^p &= (K_1, 0, 0, 0) \\ E_{\xi_2}^p &= (0, 0, 0, K_2) \\ E_{\xi_1 \xi_2}^p &= (K_1, 0, 0, K_2) \\ E_{\xi_1 y}^p &= K_1 \left(e_{y\xi_1}, g_{y\xi_1}(1 - e_{y\xi_1}), 0, 0 \right) \\ E_{z \xi_2}^p &= K_2 \left(0, 0, g_{z\xi_2}(1 - e_{z\xi_2}), e_{z\xi_2} \right) \\ E_{\xi_1 y \xi_2}^p &= K_1 \left(e_{y\xi_1}, g_{y\xi_1}(1 - e_{y\xi_1}), 0, \frac{K_2}{K_1} \right) \\ E_{\xi_1 z \xi_2}^p &= K_2 \left(\frac{K_1}{K_2}, 0, g_{z\xi_2}(1 - e_{z\xi_2}), e_{z\xi_2} \right) \end{aligned}$$

The associated local stability properties are derived in Appendix C and summarized in Table 1. Observe that the positiveness of many terms appearing in the equilibrium solutions enumerated above is implied by conditions (5) for non-trivial dynamics.

4. Coexistence equilibrium states. In a coexistence equilibrium state the abundance of all species is greater than zero. In this section we enumerate the coexistence equilibrium states of systems \mathcal{S}^l , \mathcal{S}^o and \mathcal{S}^p and give conditions for their uniqueness and positiveness.

The coexistence equilibrium states associated to model (3) are solutions to the algebraic system of equations

$$A \begin{bmatrix} \xi_1 & y & z & \xi_2 \end{bmatrix}^T + b = 0$$

$\nu =$	l	o	p
E_0^ν	unstable LAS on $(0, y, z)$	unstable LAS on $(0, y, z)$	unstable LAS on $(0, y, z, 0)$
$E_{\xi_1}^\nu$	unstable LAS on $(\xi_1, 0, z)$	unstable LAS on $(\xi_1, 0, 0)$	unstable LAS on $(\xi_1, 0, z, 0)$
$E_{\xi_2}^\nu$	-	-	unstable LAS on $(0, y, 0, \xi_2)$
$E_{\xi_1 y}^\nu$	LAS when $D_{zy} < \frac{q_z + C}{\theta_{zy} K_1 g_{y\xi_1} (1 - e_{y\xi_1})}$	LAS when $D_{zy} < \frac{q_z + C}{\theta_{zy} K_1 g_{y\xi_1} (1 - e_{y\xi_1})} \left(1 - \frac{e_{y\xi_1}}{e_{z\xi_1}}\right)$	unstable LAS on $(\xi_1, y, z, 0)$
$E_{\xi_1 z}^\nu$	-	LAS when $D_{zy} > \frac{q_y}{K_1 g_{z\xi_1} (1 - e_{z\xi_1})} \left(\frac{e_{z\xi_1}}{e_{y\xi_1}} - 1\right)$	-
$E_{\xi_1 \xi_2}^\nu$	-	-	unstable LAS on $(\xi_1, 0, 0, \xi_2)$
$E_{z\xi_2}^\nu$	-	-	unstable LAS on $(0, y, z, \xi_2)$
$E_{\xi_1 y \xi_2}^\nu$	-	-	unstable LAS on $(\xi_1, y, 0, \xi_2)$
$E_{\xi_1 z \xi_2}^\nu$	-	-	LAS when $D_{zy} > \frac{q_y}{K_2 g_{z\xi_2} (1 - e_{z\xi_2})} \frac{1 - e_{y\xi_1}}{e_{y\xi_1}}$

TABLE 1. Stability properties of the non-coexistence equilibrium states (LAS=locally asymptotically stable).

where

$$A = \begin{bmatrix} -\frac{r_1}{K_1} & -D_{y\xi_1} & -D_{z\xi_1} & 0 \\ \theta_{y\xi_1} D_{y\xi_1} & 0 & -D_{zy} & 0 \\ \theta_{z\xi_1} D_{z\xi_1} & \theta_{zy} D_{zy} & 0 & \theta_{z\xi_2} D_{z\xi_2} \\ 0 & 0 & -D_{z\xi_2} & -\frac{r_2}{K_2} \end{bmatrix}, \quad b = \begin{bmatrix} r_1 \\ -q_y \\ -(q_z + C) \\ r_2 \end{bmatrix}$$

We have $\det(A) = \Delta_1 + \Delta_2 + \Delta_3$, with

$$\begin{aligned} \Delta_1 &= \theta_{y\xi_1} \theta_{z\xi_2} D_{y\xi_1}^2 D_{z\xi_2}^2 \\ \Delta_2 &= \frac{r_2}{K_2} (\theta_{y\xi_1} \theta_{zy} - \theta_{z\xi_1}) D_{y\xi_1} D_{z\xi_1} D_{zy} \\ \Delta_3 &= \theta_{zy} \frac{r_1 r_2}{K_1 K_2} D_{zy}^2 \end{aligned}$$

Term Δ_1 is zero for both \mathcal{S}^l and \mathcal{S}^o , while term Δ_2 is zero for both \mathcal{S}^l and \mathcal{S}^p . It follows that the coexistence equilibrium is unconditionally unique for \mathcal{S}^l and \mathcal{S}^p , while for \mathcal{S}^o uniqueness requires the assumption $\Delta_2 + \Delta_3 \neq 0$. The coexistence equilibrium values of the state variables will be denoted by ξ_1^* , y^* , z^* and ξ_2^* , assuming that they are uniquely defined.

1. **System \mathcal{S}^l**

The coexistence equilibrium for system \mathcal{S}^l is

$$E_{\xi_1 y z}^l = K_1 \left(1 - \frac{e_{zy}}{g_{y\xi_1}}, e_{zy}, \frac{q_y}{D_{zy} K_1} \left(\frac{1}{e_{y\xi_1}} \left(1 - \frac{e_{zy}}{g_{y\xi_1}} \right) - 1 \right) \right)$$

The equilibrium $E_{\xi_1 y z}^l$ is positive when $1 - \frac{e_{zy}}{g_{y\xi_1}} - e_{y\xi_1} > 0$, i.e.

$$D_{zy} > \frac{q_z + C}{\theta_{zy} K_1 g_{y\xi_1} (1 - e_{y\xi_1})}$$

Observe that $E_{\xi_1 y}^l$ is unstable when this condition holds, see Table 1.

2. **System \mathcal{S}^o**

The following coexistence equilibrium can be found in this case:

$$E_{\xi_1 y z}^o = \left(\xi_1^*, \frac{e_{zy}}{e_{z\xi_1}} (-\xi_1^* + K_1 e_{z\xi_1}), \frac{q_y}{D_{zy} e_{y\xi_1} K_1} (\xi_1^* - K_1 e_{y\xi_1}) \right)$$

where

$$\xi_1^* = \frac{K_1}{A^o} \left(1 - \frac{e_{zy}}{g_y \xi_1} + \frac{q_y}{g_z \xi_1 K_1 D_{zy}} \right), \quad A^o = 1 - \frac{e_{zy}}{g_y \xi_1 e_{z\xi_1}} + \frac{q_y}{g_z \xi_1 D_{zy} e_{y\xi_1} K_1}$$

The considered equilibrium is unique if $A^o \neq 0$, which is equivalent to $\Delta_2 + \Delta_3 \neq 0$. Now assume $A^o > 0$. For the positiveness of y^* and z^* respectively, we need to impose the following conditions:

$$-\xi_1^* + K_1 e_{z\xi_1} > 0 \quad \Leftrightarrow \quad D_{zy} < \frac{q_y}{K_1 g_z \xi_1 (1 - e_{z\xi_1})} \left(\frac{e_{z\xi_1}}{e_{y\xi_1}} - 1 \right) \tag{6}$$

$$\xi_1^* - K_1 e_{y\xi_1} > 0 \quad \Leftrightarrow \quad D_{zy} > \frac{q_z + C}{\theta_{zy} K_1 g_y \xi_1 (1 - e_{y\xi_1})} \left(1 - \frac{e_{y\xi_1}}{e_{z\xi_1}} \right) \tag{7}$$

Observe that (7) also implies the positiveness of ξ_1^* . Furthermore, the two conditions (6) and (7) imply the instability of $E_{\xi_1 z}^o$ and $E_{\xi_1 y}^o$, respectively. Vice versa, when $A^o < 0$ we obtain the reverse, which means that the coexistence equilibrium is positive iff $E_{\xi_1 z}^o$ and $E_{\xi_1 y}^o$ are LAS.

3. **System \mathcal{S}^p**

The following unique coexistence equilibrium can be found for \mathcal{S}^p :

$$E_{\xi_1 y z \xi_2}^p = \left(\xi_1^*, \frac{1}{\theta_{zy} D_{zy}} \frac{q_z + C}{K_2 e_{z\xi_2}} (-\xi_2^* + e_{z\xi_2} K_2), \frac{1}{D_{zy}} \frac{q_y}{K_1 e_{y\xi_1}} (\xi_1^* - e_{y\xi_1} K_1), \xi_2^* \right)$$

where ξ_1^* and ξ_2^* are the solution of the following algebraic system:

$$\begin{bmatrix} 1 & -B^p \\ A^p & 1 \end{bmatrix} \begin{bmatrix} \xi_1^* \\ \xi_2^* \end{bmatrix} = \begin{bmatrix} K_1 - B^p K_2 e_{z\xi_2} \\ K_2 + A^p K_1 e_{y\xi_1} \end{bmatrix}$$

where $A^p = \frac{q_y}{g_z \xi_2 D_{zy} K_1 e_{y\xi_1}}$, $B^p = \frac{1}{g_y \xi_1} \frac{K_1 e_{zy}}{K_2 e_{z\xi_2}}$.

Observe that such a system admits a unique solution under our assumptions. Furthermore, the positiveness of ξ_1^* is unconditional, while ξ_2^* is positive iff

$$K_2 g_z \xi_2 D_{zy} e_{y\xi_1} g_y \xi_1 + q_y (1 + g_y \xi_1 (e_{y\xi_1} - 1)) > 0$$

Finally, for the positiveness of y^* and z^* the following conditions need to be fulfilled, respectively:

$$-\xi_2^* + e_{z\xi_2} K_2 > 0 \quad \Leftrightarrow \quad D_{zy} < \frac{q_y (1 + g_y \xi_1 (1 - e_{y\xi_1}))}{(1 - e_{z\xi_2}) K_2 g_z \xi_2 e_{y\xi_1} g_y \xi_1}$$

$$\xi_1^* - e_{y\xi_1} K_1 > 0 \quad \Leftrightarrow \quad K_1 (1 - e_{y\xi_1}) + B^p K_2 (1 - e_{z\xi_2}) > 0$$

5. **Stability properties of the coexistence equilibrium states.** In this subsection we give a characterization of the (global) stability properties of the coexistence equilibrium states for systems \mathcal{S}^l , \mathcal{S}^o and \mathcal{S}^p . In defining a solution globally asymptotically stable (GAS) we only consider the asymptotic behavior of trajectories originating in the strictly positive orthant. As a preliminary remark we mention that, differently from the cases of \mathcal{S}^l and \mathcal{S}^p , the stability analysis of \mathcal{S}^o is complicated by the presence of two paths connecting the same source to the top consumer and partitioning the corresponding biomass flow.

In order to study the stability properties of system (3), we introduce the following Lyapunov function:

$$V(\xi_1, y, z, \xi_2) = c_{\xi_1} \left(\xi_1 - \xi_1^* - \xi_1^* \ln \left(\frac{\xi_1}{\xi_1^*} \right) \right) + c_y \left(y - y^* - y^* \ln \left(\frac{y}{y^*} \right) \right) \\ + c_z \left(z - z^* - z^* \ln \left(\frac{z}{z^*} \right) \right) + c_{\xi_2} \left(\xi_2 - \xi_2^* - \xi_2^* \ln \left(\frac{\xi_2}{\xi_2^*} \right) \right)$$

where c_{ξ_1} , c_y , c_z and c_{ξ_2} are arbitrary positive constants. The derivative of the considered Lyapunov function along the trajectories of system (3) is given by

$$\dot{V} = \frac{\partial V}{\partial \xi_1} \frac{\partial \xi_1}{\partial t} + \frac{\partial V}{\partial y} \frac{\partial y}{\partial t} + \frac{\partial V}{\partial z} \frac{\partial z}{\partial t} + \frac{\partial V}{\partial \xi_2} \frac{\partial \xi_2}{\partial t} \\ = c_{\xi_1} \left(1 - \frac{\xi_1^*}{\xi_1} \right) \xi_1 \left[r_1 \left(1 - \frac{\xi_1}{K_1} \right) - D_{y\xi_1} y - D_{z\xi_1} z \right] \\ + c_y \left(1 - \frac{y^*}{y} \right) y [\theta_{y\xi_1} D_{y\xi_1} \xi_1 - q_z - D_{zy} z] \\ + c_z \left(1 - \frac{z^*}{z} \right) z [\theta_{z\xi_1} D_{z\xi_1} \xi_1 + \theta_{z\xi_2} D_{z\xi_2} \xi_2 + \theta_{zy} D_{zy} y - (q_z + C)] \\ + c_{\xi_2} \left(1 - \frac{\xi_2^*}{\xi_2} \right) \xi_2 \left[r_2 \left(1 - \frac{\xi_2}{K_2} \right) - D_{z\xi_2} z \right] \\ = c_{\xi_1} (\xi_1 - \xi_1^*) \left[-\frac{r_1}{K_1} (\xi_1 - \xi_1^*) - D_{y\xi_1} (y - y^*) - D_{z\xi_1} (z - z^*) \right] \\ + c_y (y - y^*) [\theta_{y\xi_1} D_{y\xi_1} (\xi_1 - \xi_1^*) - D_{zy} (z - z^*)] \\ + c_z (z - z^*) [\theta_{z\xi_1} D_{z\xi_1} (\xi_1 - \xi_1^*) + \theta_{z\xi_2} D_{z\xi_2} (\xi_2 - \xi_2^*) + \theta_{zy} D_{zy} (y - y^*)] \\ + c_{\xi_2} (\xi_2 - \xi_2^*) \left[-\frac{r_2}{K_2} (\xi_2 - \xi_2^*) - D_{z\xi_2} (z - z^*) \right]$$

For $i = 1, 2$ and $(i_1, i_2) \in \{(y, \xi_1), (z, \xi_1), (z, y), (z, \xi_2)\}$, let $m_{\xi_i} = \frac{c_{\xi_i} r_i}{K_i}$ and $m_{i_1 i_2} = \frac{1}{2}(-c_{i_2} + c_{i_1} \theta_{i_1 i_2}) D_{i_1 i_2}$. Now, for symmetric matrices, denote by symbol (\star) each of its symmetric blocks. Then, the latter equation can be rewritten as

$$\dot{V} = X^T M X \tag{8}$$

where $X = [\xi_1 - \xi_1^*, y - y^*, z - z^*, \xi_2 - \xi_2^*]^T$ and

$$M = \begin{bmatrix} M_1 & M_2 \\ \star & M_3 \end{bmatrix}$$

with

$$M_1 = \begin{bmatrix} -m_{\xi_1} & m_{y\xi_1} & m_{z\xi_1} \\ \star & 0 & m_{zy} \\ \star & \star & 0 \end{bmatrix}, M_2 = \begin{bmatrix} 0 \\ 0 \\ m_{z\xi_2} \end{bmatrix}, M_3 = [-m_{\xi_2}]$$

We are now in a position to analyze the global asymptotic stability of the coexistence equilibrium states associated to each type of system.

1. System \mathcal{S}^l

We have to evaluate the corresponding components of \dot{V} in (8) in the state

space (ξ_1, y, z) . Matrix M_1 reduces to the following form M_1^l :

$$M_1^l = \begin{bmatrix} -m_{\xi_1} & m_{y\xi_1} & 0 \\ \star & 0 & m_{zy} \\ \star & \star & 0 \end{bmatrix}$$

It is easy to show that $c_{\xi_1}, c_y, c_z > 0$ can be chosen so that $m_{y\xi_1} = m_{zy} = 0$. Thus, the resulting derivative of the Lyapunov function along the trajectories of \mathcal{S}^l is equal to

$$\dot{V} = -m_{\xi_1}(\xi_1 - \xi_1^*)^2$$

This quantity is zero *iff* $\xi_1 = \xi_1^*$. The following implications hold:

$$\begin{aligned} \xi_1 = \xi_1^* &\Rightarrow \dot{\xi}_1 = 0 \Rightarrow y = \frac{r_1}{D_{y\xi_1}} \left(1 - \frac{\xi_1^*}{K_1} \right) = y^* \Rightarrow \dot{y} = 0 \\ &\Rightarrow z = \frac{1}{D_{zy}} (\theta_{y\xi_1} D_{y\xi_1} \xi_1^* - q_y) = z^* \Rightarrow \dot{z} = 0 \end{aligned}$$

so that the associated invariant set is (ξ_1^*, y^*, z^*) . Thus, $E_{\xi_1 y z}^l$ is GAS.

2. System \mathcal{S}^o

Matrix M_1 reduces to the following form:

$$M_1^o = \begin{bmatrix} -m_{\xi_1} & m_{y\xi_1} & m_{z\xi_1} \\ \star & 0 & m_{zy} \\ \star & \star & 0 \end{bmatrix}$$

In order to prove that $\dot{V} < 0$ we impose that the cross-product terms are zero, i.e. $m_{y\xi_1} = m_{z\xi_1} = m_{zy} = 0$. It is always possible to define $c_{\xi_1}, c_y, c_z > 0$ solving the problem when the following condition holds:

$$\theta_{z\xi_1} = \theta_{zy}\theta_{y\xi_1}$$

This assumption ensures that the cross-product terms appearing in the Lyapunov function's derivative are zero. The efficiency gap $\theta_{z\xi_1} - \theta_{zy}\theta_{y\xi_1}$ plays a fundamental role in determining the stability properties \mathcal{S}^o . To better emphasize this point, it is possible to perform a local stability analysis of the coexistence equilibrium of \mathcal{S}^o , which results in the following characteristic polynomial:

$$\begin{aligned} \mathcal{P}_{\xi_1 y z}^o = & -\lambda^3 - r_1 \frac{\xi_1^*}{K_1} \lambda^2 - (\theta_{y\xi_1} D_{y\xi_1}^2 \xi_1^* y^* + \theta_{z\xi_1} D_{z\xi_1}^2 \xi_1^* z^* + \theta_{zy} D_{zy}^2 y^* z^*) \lambda \\ & + \left((\theta_{z\xi_1} - \theta_{zy}\theta_{y\xi_1}) D_{y\xi_1} D_{z\xi_1} D_{zy} \xi_1^* y^* z^* - r_1 \frac{\xi_1^*}{K_1} \theta_{zy} D_{zy}^2 y^* z^* \right) \lambda \end{aligned}$$

Using the Routh-Hurwitz theorem, we conclude that the following condition implies that the coexistence equilibrium is LAS:

$$\theta_{z\xi_1} - \theta_{zy}\theta_{y\xi_1} < \frac{2r_1\theta_{zy}D_{zy}}{K_1 D_{y\xi_1} D_{z\xi_1}}$$

3. System \mathcal{S}^p

We refer to the following matrix M^p , obtained from M as a particular case:

$$M^p = \begin{bmatrix} -m_{\xi_1} & m_{y\xi_1} & 0 & 0 \\ \star & 0 & m_{zy} & 0 \\ \star & \star & 0 & m_{z\xi_2} \\ \star & \star & \star & -m_{\xi_3} \end{bmatrix}$$

It is easy to show that $c_{\xi_1}, c_y, c_z, c_{\xi_2} > 0$ can be chosen so that $m_{y\xi_1} = m_{zy} = m_{z\xi_2} = 0$. The resulting derivative of the Lyapunov function along the trajectories of \mathcal{S}^p is

$$\dot{V} = -m_{\xi_1}(\xi_1 - \xi_1^*)^2 - m_{\xi_2}(\xi_2 - \xi_2^*)^2$$

This quantity is zero iff $\xi_1 = \xi_1^*$ and $\xi_2 = \xi_2^*$. The following implications hold:

$$\begin{aligned} \begin{cases} \xi_1 = \xi_1^* \\ \xi_2 = \xi_2^* \end{cases} &\Rightarrow \begin{cases} \dot{\xi}_1 = 0 \\ \dot{\xi}_2 = 0 \end{cases} \Rightarrow \begin{cases} 0 = r_1 \left(1 - \frac{\xi_1^*}{K_1}\right) - D_{y\xi_1}y \\ 0 = r_2 \left(1 - \frac{\xi_2^*}{K_2}\right) - D_{z\xi_2}z \end{cases} \\ &\Rightarrow \begin{cases} y = y^* \\ z = z^* \end{cases} \Rightarrow \begin{cases} \dot{y} = 0 \\ \dot{z} = 0 \end{cases} \end{aligned}$$

Thus the associated invariant set reduces to $(\xi_1^*, y^*, z^*, \xi_2^*)$ and we conclude that $E_{\xi_1 y z \xi_2}^p$ is GAS.

6. Optimal control. In this section we introduce an optimal control problem associated to system (3). The objective of our control strategies will be to maximize a suitable societal objective functional in order to enhance the human population level z and the utility function $W(C)$, defined according to the assumptions (1). In our setup, from now on quantities $C, D_{z\xi_1}, D_{z\xi_2}$ and D_{zy} are considered control variables whose value along time has to be assigned so to maximize the following societal objective function [32, 14]:

$$\max_{C, D_{z\xi_1}, D_{zy}, D_{z\xi_2}} \int_0^\infty e^{-\delta t} z(t) W(C(t)) dt \tag{9}$$

subject to the system of ODEs (3) and

$$D_{z\xi_1} \in [0, D_{z\xi_1}^{ub}], D_{zy} \in [0, D_{zy}^{ub}], D_{z\xi_2} \in [0, D_{z\xi_2}^{ub}]$$

In this formulation, $e^{-\delta t}$ is the discount term, with $\delta > 0$ fixed [42], and the positive constants $D_{z\xi_1}^{ub}, D_{zy}^{ub}$ and $D_{z\xi_2}^{ub}$ express technical/technological limitations encountered in the human food catching process and are assumed to be constant in time. Observe that the effective number of control variables involved in the management of the trophic system, as well as the dimension of the ODE system itself, depends on the specific food chain under consideration. In particular, the control variables C and D_{zy} are common to all cases, while each of the chains \mathcal{S}^o and \mathcal{S}^p includes an additional control variable, either $D_{z\xi_1}$ or $D_{z\xi_2}$. Therefore, all the trophic chains we are considering have a so-called top-down structure from the control point of view, i.e. the control variables are associated to the regulation of the behavior of the top level consumer.

In order to tackle the optimal control problem (9), we apply the Pontryagin maximum principle. To do so, we reformulate problem (9) as the maximization of the Hamiltonian

$$H = e^{-\delta t} z W(C) + \lambda^T F \tag{10}$$

where $\lambda = [\lambda_1 \ \lambda_2 \ \lambda_3 \ \lambda_4]^T$ is the costate vector and $F = [F_{\xi_1} \ F_y \ F_z \ F_{\xi_2}]^T$ collects the right-hand sides of the equations in system (3). Now let $X = [\xi_1, y, z, \xi_2]^T$, $U = [C, D_{z\xi_1}, D_{z\xi_2}, D_{zy}]^T$ and define the following Hamiltonian system associated to the optimal control problem under analysis:

$$\begin{cases} \dot{X} &= \frac{\partial H}{\partial \lambda} = F \\ \dot{\lambda} &= \left[-\frac{\partial H}{\partial X}\right]^T = A^H \lambda + B^H \end{cases}$$

where

$$A^H = \begin{bmatrix} A_{11}^H & A_{12}^H \\ A_{21}^H & A_{22}^H \end{bmatrix}, \quad B^H = \begin{bmatrix} B_1^H \\ B_2^H \end{bmatrix}$$

and

$$\begin{aligned} A_{11}^H &= \begin{bmatrix} -\frac{F_{\xi_1}}{\xi_1} + r_1 \frac{\xi_1}{K_1} & -\theta_{y\xi_1} D_{y\xi_1} y & -\theta_{z\xi_1} D_{z\xi_1} z \\ D_{y\xi_1} \xi_1 & -\frac{F_y}{y} & -\theta_{zy} D_{zy} z \\ D_{z\xi_1} \xi_1 & D_{zy} y & -\frac{F_z}{z} \end{bmatrix} & A_{12}^H &= \begin{bmatrix} 0 \\ 0 \\ D_{z\xi_2} \xi_2 \end{bmatrix} \\ A_{21}^H &= \begin{bmatrix} 0 & 0 & -\theta_{z\xi_2} D_{z\xi_2} z \end{bmatrix} & A_{22}^H &= \begin{bmatrix} -\frac{F_{\xi_2}}{\xi_2} + r_2 \frac{\xi_2}{K_2} \end{bmatrix} \\ B_1^H &= \begin{bmatrix} 0 \\ 0 \\ -e^{-\delta t} W(C) \end{bmatrix} & B_2^H &= [0] \end{aligned}$$

Clearly, this system is defined in structure and size by the specific type of trophic chain we are considering. We report next the necessary conditions for an optimal solution according to the Pontryagin maximum principle, assuming that such an optimum exists:

$$0 = \frac{\partial H}{\partial u_i}, \quad \forall i \quad (11)$$

$$0 = \lim_{t \rightarrow \infty} \lambda_i(t), \quad \forall i \quad (12)$$

where u_i is the i -th component of vector U .

Observe that, when the dynamical solution of the optimal control problem (9) is considered, singularity is found with respect to the control variables $D_{z\xi_1}$, D_{zy} and $D_{z\xi_2}$. This can be easily observed by writing the current-value Hamiltonian H_c associated to (10) as follows:

$$H_c = \alpha(\lambda, \xi_1, y, z, \xi_2) [D_{z\xi_1} \ D_{zy} \ D_{z\xi_2}]^T + (zW(C) - \lambda_3 zC) + \beta(\lambda, \xi_1, y, z, \xi_2)$$

where

$$\begin{aligned} \alpha(\lambda, \xi_1, y, z, \xi_2) &= [(-\lambda_1 + \lambda_3 \theta_{z\xi_1}) \xi_1 z \quad (-\lambda_2 + \lambda_3 \theta_{zy}) y z \quad (-\lambda_4 + \lambda_3 \theta_{z\xi_2}) \xi_2 z] \\ \beta(\lambda, \xi_1, y, z, \xi_2) &= \lambda_1 \xi_1 \left[r_1 \left(1 - \frac{\xi_1}{K_1} \right) - D_{y\xi_1} y \right] + \lambda_2 y [\theta_{y\xi_1} D_{y\xi_1} \xi_1 - q_y] \\ &\quad - \lambda_3 z q_z + \lambda_4 \xi_2 \left[r_2 \left(1 - \frac{\xi_2}{K_2} \right) \right] \end{aligned}$$

It results that, if an optimal solution is such that some components of $\alpha(\lambda, \xi_1, y, z, \xi_2)$ are zero for $t \in [t_1, t_2]$, $t_1 < t_2$, the state trajectory has a singular arc. When this does not happen, the time evolution of the optimal control variables $D_{z\xi_1}$, D_{zy} and $D_{z\xi_2}$ is bang-bang, i.e. $D_{z\xi_1} \in \{0, D_{z\xi_1}^{ub}\}$, $D_{zy} \in \{0, D_{zy}^{ub}\}$, and $D_{z\xi_2} \in \{0, D_{z\xi_2}^{ub}\}$.

From now on in this paper, we focus on giving a characterization of the optimal static control policies for \mathcal{S}^l , \mathcal{S}^o and \mathcal{S}^p , consisting in the constant controls associated to the optimal final steady-states for the dynamic optimal control problem (9). To this end, we also neglect the upper bounds $D_{z\xi_1}^{ub}$, $D_{z\xi_2}^{ub}$ and D_{zy}^{ub} on the control variables. In studying the optimal static control policies, we refer to the asymptotic behavior of the optimal state trajectories encountered in (9). As emphasized in [12], this kind of analysis can be very informative and enable us to evaluate the sensitivity of the optimal limit points of the state trajectories to relevant parameters of the optimization problem, such as the discount rate δ .

1. System \mathcal{S}^l

The adjoint system reduces to

$$\dot{\lambda}^l = A_{11}^H \lambda^l + B_1^H \quad (13)$$

where $\lambda^l = [\lambda_1^l, \lambda_2^l, \lambda_3^l]^T$; recall that, in this case, $D_{z\xi_1} = 0$ by assumption.

In order to compute the optimal static solution, we first manipulate system (13), obtaining the following ODE in λ_2^l by elimination:

$$\lambda_2^{l(3)} + \alpha_{21}^l \ddot{\lambda}_2^l + \alpha_{22}^l \dot{\lambda}_2^l + \alpha_{23}^l \lambda_2^l + \beta_2^l e^{-\delta t} W(C) = 0 \quad (14)$$

with

$$\begin{aligned} \alpha_{21}^l &= -r_1 \frac{\xi_1}{K_1} \\ \alpha_{22}^l &= \theta_{y\xi_1} D_{y\xi_1}^2 \xi_1 y + \theta_{zy} D_{zy}^2 y z \\ \alpha_{23}^l &= -r_1 \frac{\xi_1}{K_1} \theta_{zy} D_{zy}^2 y z \\ \beta_2^l &= \theta_{zy} D_{zy} z \left(\delta + r_1 \frac{\xi_1}{K_1} \right) \end{aligned}$$

The associated complete solution is of the form

$$\lambda_2^l = M_{21}^l e^{\mu_{21} t} + M_{22}^l e^{\mu_{22} t} + M_{23}^l e^{\mu_{23} t} + N_2^l e^{-\delta t} W(C)$$

where M_{21}^l , M_{22}^l and M_{23}^l are arbitrary constants,

$$N_2^l = \frac{\beta_2^l}{\delta^3 - \alpha_{21}^l \delta^2 + \alpha_{22}^l \delta - \alpha_{23}^l}$$

and coefficients μ_{2i} , $i = 1, 2, 3$ are solutions of the auxiliary equation for (14), namely

$$\mu^3 + \alpha_{21}^l \mu^2 + \alpha_{22}^l \mu + \alpha_{23}^l = 0$$

By studying the latter equation it is possible to conclude that, in order to have $\lim_{t \rightarrow \infty} \lambda_2^l = 0$, as requested in (12) for optimality, we must impose $M_{21}^l = M_{22}^l = M_{23}^l = 0$.

We can proceed similarly for λ_3^l , obtaining the following ODE by elimination:

$$\lambda_3^{l(3)} + \alpha_{31}^l \ddot{\lambda}_3^l + \alpha_{32}^l \dot{\lambda}_3^l + \alpha_{33}^l \lambda_3^l + \beta_3^l e^{-\delta t} W(C) = 0 \quad (15)$$

with

$$\begin{aligned} \alpha_{3i}^l &= \alpha_{2i}^l, \quad i = 1, 2, 3 \\ \beta_3^l &= \delta^2 + r_1 \frac{\xi_1}{K_1} \delta + \theta_{y\xi_1} D_{y\xi_1}^2 \xi_1 y \end{aligned}$$

The complete solution, in this case, has the form

$$\lambda_3^l = M_{31}^l e^{\mu_{31} t} + M_{32}^l e^{\mu_{32} t} + M_{33}^l e^{\mu_{33} t} + N_3^l e^{-\delta t} W(C)$$

where M_{31}^l , M_{32}^l and M_{33}^l are arbitrary constants,

$$N_3^l = \frac{\beta_3^l}{\delta^3 - \alpha_{31}^l \delta^2 + \alpha_{32}^l \delta - \alpha_{33}^l}$$

and coefficients μ_{3i} , $i = 1, 2, 3$ solve the auxiliary equation for (15), which is

$$\mu^3 + \alpha_{31}^l \mu^2 + \alpha_{32}^l \mu + \alpha_{33}^l = 0$$

Similarly to the previous case, it is possible to verify that the optimality condition $\lim_{t \rightarrow \infty} \lambda_3^l = 0$ is fulfilled if and only if $M_{31}^l = M_{32}^l = M_{33}^l = 0$.

Thanks to the calculations reported above, we can now deal with the optimality condition (11). Since we are considering optimal coexistence equilibrium states and thus $y, z > 0$ by assumption, it results

$$\begin{cases} \frac{\partial H}{\partial C} = (-\lambda_3^l + e^{-\delta t} W'(C))z = 0 \\ \frac{\partial H}{\partial D_{zy}} = (-\lambda_2^l + \lambda_3^l \theta_{zy}) yz = 0 \end{cases} \Leftrightarrow \begin{cases} \lambda_2^l = \theta_{zy} e^{-\delta t} W'(C) \\ \lambda_3^l = e^{-\delta t} W'(C) \end{cases}$$

Substituting λ_2^l and λ_3^l therein according to the expressions found above, we obtain the following algebraic optimality conditions in the variables C, D_{zy}, ξ_1, y and z :

$$\begin{cases} N_2^l W(C) & = \theta_{zy} W'(C) \\ N_3^l W(C) & = W'(C) \\ r_1 \left(1 - \frac{\xi_1}{K_1}\right) - D_{y\xi_1} y & = 0 \\ \theta_{y\xi_1} D_{y\xi_1} \xi_1 - q_y - D_{zy} z & = 0 \\ \theta_{zy} D_{zy} y - (q_z + C) & = 0 \end{cases} \quad (16)$$

2. System \mathcal{S}^o

The adjoint system in this case is

$$\dot{\lambda}^o = A_{11}^H \lambda^o + B_1^H \quad (17)$$

where $\lambda^o = [\lambda_1^o, \lambda_2^o, \lambda_3^o]^T$ and, differently from the previous case, $D_{z\xi_1} > 0$ by assumption.

Operating on (17) by elimination, we obtain the following ODE in λ_j^o , $j = 1, 2, 3$:

$$\lambda_j^{o(3)} + \alpha_{j1}^o \ddot{\lambda}_j^o + \alpha_{j2}^o \dot{\lambda}_j^o + \alpha_{j3}^o \lambda_j^o + \beta_j^o e^{-\delta t} W(C) = 0 \quad (18)$$

with

$$\begin{aligned} \alpha_{j1}^o &= -r_1 \frac{\xi_1}{K_1} \\ \alpha_{j2}^o &= \theta_{y\xi_1} D_{y\xi_1}^2 \xi_1 y + \theta_{z\xi_1} D_{z\xi_1}^2 \xi_1 z + \theta_{zy} D_{zy}^2 yz \\ \alpha_{j3}^o &= -r_1 \frac{\xi_1}{K_1} \theta_{zy} D_{zy}^2 yz + (\theta_{z\xi_1} - \theta_{zy} \theta_{y\xi_1}) D_{y\xi_1} D_{z\xi_1} D_{zy} \xi_1 yz \\ \beta_1^o &= \theta_{z\xi_1} D_{z\xi_1} z \delta + \theta_{y\xi_1} \theta_{zy} D_{y\xi_1} D_{zy} yz \\ \beta_2^o &= \theta_{zy} D_{zy} z \delta + r_1 \frac{\xi_1}{K_1} \theta_{zy} D_{zy} z - \theta_{z\xi_1} D_{y\xi_1} D_{z\xi_1} \xi_1 z \\ \beta_3^o &= \delta^2 + r_1 \frac{\xi_1}{K_1} \delta + \theta_{y\xi_1} D_{y\xi_1}^2 \xi_1 y \end{aligned}$$

The associated complete solution is of the form

$$\lambda_j^o = \sum_{i=1}^3 (M_{ji}^o e^{\mu_{ji} t}) + N_j^o e^{-\delta t} W(C)$$

where M_{ji}^o , $i = 1, \dots, 3$, $j = 1, 2, 3$ are arbitrary constants, while

$$N_j^o = \frac{\beta_j^o}{\delta^3 - \alpha_{j1}^o \delta^2 + \alpha_{j2}^o \delta - \alpha_{j3}^o}$$

and coefficients μ_{ji} , $i = 1, \dots, 4$, $j = 1, 3$ are solutions of the auxiliary equation for (18), namely

$$\mu^3 + \alpha_{j1}^o \mu^2 + \alpha_{j2}^o \mu + \alpha_{j3}^o = 0$$

By some computation it results that, in order to have $\lim_{t \rightarrow \infty} \lambda_j^o = 0$, as requested in (12) for optimality, we impose $M_{ji}^o = 0$, $i = 1, \dots, 4$, $j = 1, 2, 3$.

Thanks to the calculations reported above, we can now deal with the optimality condition (11). Since we are considering optimal coexistence equilibrium states and thus $y, z > 0$ by assumption, it results

$$\begin{cases} \frac{\partial H}{\partial C} = (-\lambda_3^o + e^{-\delta t} W'(C))z = 0 \\ \frac{\partial H}{\partial D_{z\xi_1}} = (-\lambda_1^o + \lambda_3^o \theta_{z\xi_1}) \xi_1 z = 0 \\ \frac{\partial H}{\partial D_{zy}} = (-\lambda_2^o + \lambda_3^o \theta_{zy}) yz = 0 \end{cases} \Leftrightarrow \begin{cases} \lambda_1^o = \theta_{z\xi_1} e^{-\delta t} W'(C) \\ \lambda_2^o = \theta_{zy} e^{-\delta t} W'(C) \\ \lambda_3^o = e^{-\delta t} W'(C) \end{cases}$$

Substituting λ_1^o , λ_2^o and λ_3^o therein according to the expressions found above, we obtain the following algebraic optimality conditions in the variables C , $D_{z\xi_1}$, D_{zy} , ξ_1 , y and z :

$$\begin{cases} N_1^o W(C) = \theta_{z\xi_1} W'(C) \\ N_2^o W(C) = \theta_{zy} W'(C) \\ N_3^o W(C) = W'(C) \\ r_1 \left(1 - \frac{\xi_1}{K_1}\right) - D_{y\xi_1} y - D_{z\xi_1} z = 0 \\ \theta_{y\xi_1} D_{y\xi_1} \xi_1 - q_y - D_{zy} z = 0 \\ \theta_{z\xi_1} D_{z\xi_1} \xi_1 + \theta_{zy} D_{zy} y - (q_z + C) = 0 \end{cases}$$

3. System \mathcal{S}^p

The adjoint system in this case is

$$\dot{\lambda}^p = A^H \lambda^p + B^H \quad (19)$$

where $\lambda^p = [\lambda_1^p, \lambda_2^p, \lambda_3^p, \lambda_4^p]^T$ and, in A^H , $D_{z\xi_1} = 0$ by assumption.

Similarly to the previous cases, in order to compute the optimal static solution we manipulate system (19) by elimination. In this way, we obtain the following ODE in λ_j^p , with $j = 2, 3, 4$:

$$\lambda_j^{p(4)} + \alpha_{j1}^p \lambda_j^{p(3)} + \alpha_{j2}^p \ddot{\lambda}_j^p + \alpha_{j3}^p \dot{\lambda}_j^p + \alpha_{j4}^p \lambda_j^p + \beta_j^p e^{-\delta t} W(C) = 0 \quad (20)$$

with

$$\begin{aligned}
 \alpha_{j1}^p &= -\left(r_1 \frac{\xi_1}{K_1} + r_2 \frac{\xi_2}{K_2}\right) \\
 \alpha_{j2}^p &= \theta_{y\xi_1} D_{y\xi_1}^2 \xi_1 y + \theta_{zy} D_{zy}^2 yz + \theta_{z\xi_2} D_{z\xi_2}^2 \xi_2 z + r_1 \frac{\xi_1}{K_1} r_2 \frac{\xi_2}{K_2} \\
 \alpha_{j3}^p &= -r_1 \frac{\xi_1}{K_1} z (\theta_{zy} D_{zy}^2 y + \theta_{z\xi_2} D_{z\xi_2}^2 \xi_2) - r_2 \frac{\xi_2}{K_2} y (\theta_{y\xi_1} D_{y\xi_1}^2 \xi_1 + \theta_{zy} D_{zy}^2 z) \\
 \alpha_{j4}^p &= \left(\theta_{y\xi_1} D_{y\xi_1}^2 \theta_{z\xi_2} D_{z\xi_2}^2 + \frac{r_1}{K_1} \frac{r_2}{K_2} \theta_{zy} D_{zy}^2\right) \xi_1 \xi_2 yz \\
 \beta_2^p &= -\theta_{zy} D_{zy} z \left(\delta^2 + \left(r_1 \frac{\xi_1}{K_1} + r_2 \frac{\xi_2}{K_2}\right) \delta - r_1 \frac{\xi_1}{K_1} r_2 \frac{\xi_2}{K_2}\right) \\
 \beta_3^p &= -\delta^3 - \left(r_1 \frac{\xi_1}{K_1} + r_2 \frac{\xi_2}{K_2}\right) \delta^2 - \left(r_1 \frac{\xi_1}{K_1} r_2 \frac{\xi_2}{K_2} + \theta_{y\xi_1} D_{y\xi_1}^2 \xi_1 y\right) \delta \\
 &\quad - \theta_{y\xi_1} D_{y\xi_1}^2 \xi_1 y r_2 \frac{\xi_2}{K_2} \\
 \beta_4^p &= -\theta_{z\xi_2} D_{z\xi_2} z \left(\delta^2 + r_1 \frac{\xi_1}{K_1} \delta + \theta_{y\xi_1} D_{y\xi_1}^2 \xi_1 y\right)
 \end{aligned}$$

The associated complete solution is of the form

$$\lambda_j^p = \sum_{i=1}^4 (M_{ji}^p e^{\mu_{ji} t}) + N_j^p e^{-\delta t} W(C)$$

where M_{ji}^p , $i = 1, \dots, 4$, $j = 2, 3, 4$ are arbitrary constants, while

$$N_j^p = \frac{\beta_j^p}{-\delta^4 + \alpha_{j1}^p \delta^3 - \alpha_{j2}^p \delta^2 + \alpha_{j3}^p \delta - \alpha_{j4}^p}$$

and coefficients μ_{ji} , $i = 1, \dots, 4$ are solutions of the auxiliary equation for (20), namely

$$\mu^4 + \alpha_{j1}^p \mu^3 + \alpha_{j2}^p \mu^2 + \alpha_{j3}^p \mu + \alpha_{j4}^p = 0$$

By some computation it results that, in order to have $\lim_{t \rightarrow \infty} \lambda_j^p = 0$, as requested in (12) for optimality, we must have $M_{2i}^p = 0$, $i = 1, \dots, 4$, $j = 2, 3, 4$.

It is now possible to address the optimality condition (11). Since we are considering optimal coexistence equilibrium states and thus $y, z > 0$ by assumption, it results

$$\begin{cases} \frac{\partial H}{\partial C} &= (-\lambda_3^p + e^{-\delta t} W'(C))z &= 0 \\ \frac{\partial H}{\partial D_{zy}} &= (-\lambda_2^p + \lambda_3^p \theta_{zy}) yz &= 0 \\ \frac{\partial H}{\partial D_{z\xi_2}} &= (-\lambda_4^p + \lambda_3^p \theta_{z\xi_2}) y \xi_2 &= 0 \end{cases} \Leftrightarrow \begin{cases} \lambda_2^p &= \theta_{zy} e^{-\delta t} W'(C) \\ \lambda_3^p &= e^{-\delta t} W'(C) \\ \lambda_4^p &= \theta_{z\xi_2} e^{-\delta t} W'(C) \end{cases}$$

Substituting λ_2^p , λ_3^p and λ_4^p therein according to the expressions found above, we obtain the following algebraic optimality conditions in the variables C ,

$D_{zy}, D_{z\xi_2}, \xi_1, y, z$ and ξ_2 :

$$\begin{cases} N_2^p W(C) & = \theta_{zy} W'(C) \\ N_3^p W(C) & = W'(C) \\ N_4^p W(C) & = \theta_{z\xi_2} W'(C) \\ r_1 \left(1 - \frac{\xi_1}{K_1}\right) - D_{y\xi_1} y & = 0 \\ \theta_{y\xi_1} D_{y\xi_1} \xi_1 - q_y - D_{zy} z & = 0 \\ \theta_{zy} D_{zy} y + \theta_{z\xi_2} D_{z\xi_2} \xi_2 - (q_z + C) & = 0 \\ r_2 \left(1 - \frac{\xi_2}{K_2}\right) - D_{z\xi_2} z & = 0 \end{cases} \quad (21)$$

7. Numerical examples. This section presents some numerical studies related to the optimal control problem discussed in the previous section. Specifically, we assume $W(C) = \frac{C}{a_C + C}$, where $a_C > 0$ is a constant, and focus on the optimal static solutions of systems \mathcal{S}^l and \mathcal{S}^p as functions of δ . Our simulations are based on a parameter set derived from the literature and reported in the following table:

par.	value	definition	ref.
r_1	0.005 (day)^{-1}	specific growth rate of pasture biomass	[29, 24]
K_1	0.12 Kg/m^2	carrying capacity of pasture	[29, 24]
r_2	0.004 (day)^{-1}	specific growth rate of crop biomass	[27]
K_2	0.1 Kg/m^2	carrying capacity of crop	[27]
q_y	$0.000788 \text{ (day)}^{-1}$	herbivore biomass loss rate	[13]
q_z	$0.0000505 \text{ (day)}^{-1}$	human biomass loss rate	[34]
$D_{y\xi_1}$	$0.19 \text{ m}^2/(\text{day} \cdot \text{Kg})$	demand related parameter	[20]
$\theta_{y\xi_1}$	0.1	herbivore conversion efficiency	[a]
$\theta_{z\xi_2}$	0.01	human conversion efficiency for crop	[b]
θ_{zy}	0.19	human conversion efficiency for herb.	[a]
a_C	0.1 (day)^{-1}	coefficient appearing in function $W(C)$	(assump.)

TABLE 2. Model parameters ([a]: Prof. A. Caroli, University of Brescia, Italy, personal communication; [b]: derived from *H.I.* \times $e_{z\xi_1}$, assuming *H.I.* (harvest index) = 0.1).

Observe that this parameter set fulfills the condition related to $e_{y\xi_1}$ for non-triviality in (5) (observe that this is the only non-triviality condition purely dependent on data and not on controls), since it results $e_{y\xi_1} \approx 0.35 < 1$.

We begin by considering \mathcal{S}^l . By solving the algebraic system (16) parametrically with respect to δ , we obtain the results reported in Figure 3. Some interesting discussion can be made based on these solutions. To this end, recall that present utility prevails over long-run profits in determining the value of the societal objective function, when the value of δ increases. Inversely, for low values of the parameter the human population level and consumption are limited in order to preserve trophic resources useful for human consumption. This is confirmed by our numerical analysis: consumption C increases with δ and is supported by the simultaneous increase of D_{zy} . The high level of exploitation of the herbivore biomass by humans for high values of δ reduces the relative static optimal equilibrium value.

As a second step, we study the case of \mathcal{S}^p and solve the algebraic system (21) as a function of parameter δ . The outcomes of this procedure are displayed in Figure 4. In particular, observe the ability of this system's configuration to allow

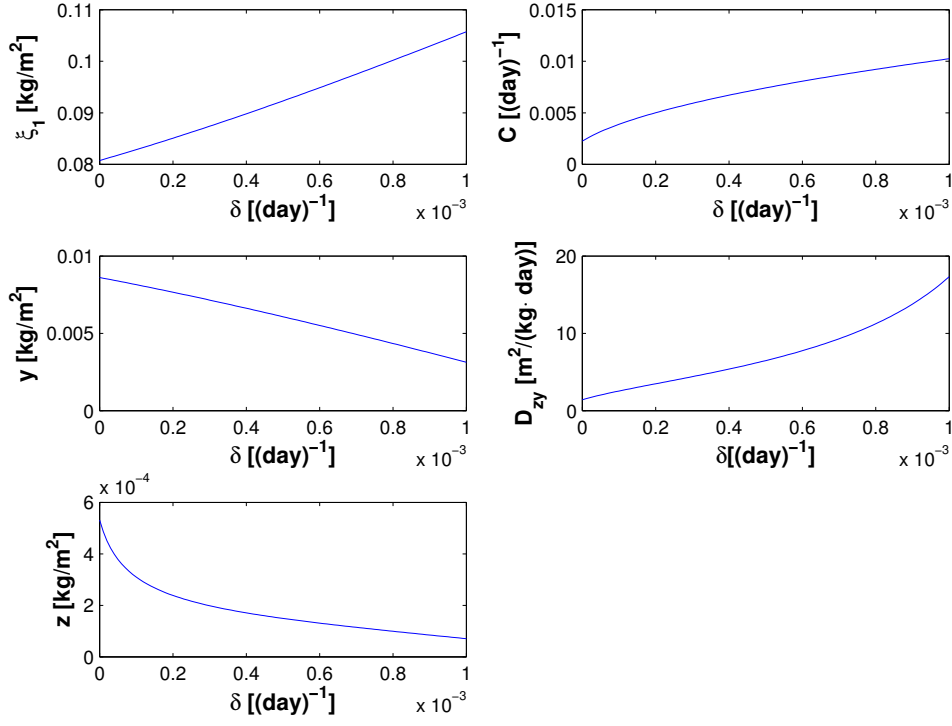

FIGURE 3. System \mathcal{S}^l : optimal steady states and control inputs as functions of δ .

higher values of z with respect to the case of \mathcal{S}^l discussed above, thanks to the support now provided by the second plant source.

8. Concluding remarks. In this paper we examined three Lotka-Volterra tritrophic chains: a linear chain \mathcal{S}^l , a trophic chain with omnivory \mathcal{S}^o and a trophic chain with omnivory and source partition \mathcal{S}^p . We identified the equilibrium solutions of each system and also analyzed the related stability properties. In the case of systems \mathcal{S}^l and \mathcal{S}^p , we showed GAS using a standard Lyapunov method. In studying the stability of \mathcal{S}^o , we discussed the special role played by $\theta_{z\xi_1} - \theta_{zy}\theta_{y\xi_1}$, which represents the efficiency gap between the two trophic channels humans exploit to draw biomass from the food source.

We also formulated an optimal control problem to determine the rates at which humans consume biomass from the lower levels of the trophic chain and the rate at which humans lose biomass to gain utility, in order to enhance a combination of utility and human biomass over an infinite time horizon.

Using data from Sub-Saharan Africa, we gave some numerical characterizations about how stationary optimal solutions vary with respect to parameter δ . It is interesting to observe how these relationships depend qualitatively on the model's structure. Specifically, comparing the case of \mathcal{S}^p with \mathcal{S}^l , we appreciated the effect of a second plant food source on the ability to maintain higher human biomass levels with respect to parameter δ .

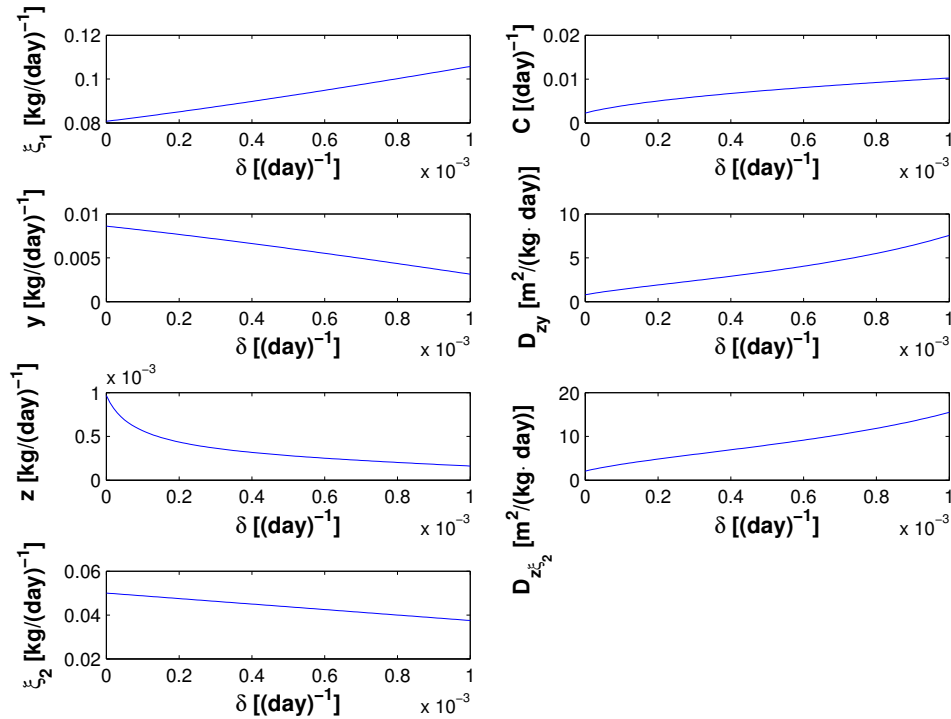

FIGURE 4. System S^p : optimal steady states and control inputs as functions of δ .

Acknowledgments. Project partially funded by the Milano City Council under the program “Milano per la difesa, incremento e valorizzazione della biodiversità. Contributi a favore della solidarietà e della cooperazione internazionale - anno 2009”. The authors gratefully thank Prof. A. Caroli, University of Brescia, Italy, for the useful discussion on the model parameters used in Section 7 of this paper.

Appendices.

Appendix A. Proof of Theorem 2.1. The two properties stated in the theorem are demonstrated separately.

Part 1. Positive invariance. If $(\xi_1^0, y^0, z^0, \xi_2^0) \in \Omega$, then

Step 1: for $i = 1, 2$, $0 \leq \xi_i(t) \leq K_i$, $\forall t \geq 0$.

This property is a direct consequence of a standard comparison theorem and is easily demonstrated referring to the differential inequality $\dot{\xi}_i \leq r_i \xi_i (1 - \frac{\xi_i}{K_i})$ characterizing the time evolution of the state variables ξ_i , for $i = 1, 2$ and applying the Gronwall’s inequality.

Step 2: $0 \leq \xi_1(t) + \frac{y(t)}{\theta_y \xi_1} \leq K_1 + \frac{r_1}{q_y} \frac{K_1}{4}$, $\forall t \geq 0$.

The following inequalities hold:

$$\begin{aligned}\dot{\xi}_1 + \frac{\dot{y}}{\theta_{y\xi_1}} &\leq -q_y \left(\xi_1 + \frac{y}{\theta_{y\xi_1}} \right) + q_y \xi_1 + r_1 \xi_1 \left(1 - \frac{\xi_1}{K_1} \right) \\ &\leq -q_y \left(\xi_1 + \frac{y}{\theta_{y\xi_1}} \right) + q_y K_1 + r_1 \frac{K_1}{4}\end{aligned}$$

As a consequence, by Gronwall's inequality, $\forall t \geq 0$ we have

$$\begin{aligned}\xi_1(t) + \frac{y(t)}{\theta_{y\xi_1}} &\leq \left(K_1 + \frac{r_1 K_1}{q_y} \frac{1}{4} \right) - e^{-q_y t} \left[\left(K_1 + \frac{r_1 K_1}{q_y} \frac{1}{4} \right) - \left(\xi_1^0 + \frac{y^0}{\theta_{y\xi_1}} \right) \right] \\ &\leq K_1 + \frac{r_1 K_1}{q_y} \frac{1}{4}\end{aligned}$$

Step 3: $0 \leq \xi_1 + \frac{y}{\theta_{y\xi_1}} + \frac{z}{\theta_{y\xi_1}\theta_{zy}} + \frac{\theta_{z\xi_2}\xi_2}{\theta_{y\xi_1}\theta_{zy}} \leq K_1 + \frac{r_1 K_1}{q_y} \frac{1}{4} + \frac{1}{q_z + C} \left(\frac{r_1 K_1}{4} + \frac{\theta_{z\xi_2} r_2}{\theta_{y\xi_1}\theta_{zy}} \frac{K_2}{4} \right) + \frac{\theta_{z\xi_2}}{\theta_{y\xi_1}\theta_{zy}} K_2$, $\forall t \geq 0$.

The following inequality holds in this case:

$$\begin{aligned}\dot{\xi}_1 + \frac{\dot{y}}{\theta_{y\xi_1}} + \frac{\dot{z}}{\theta_{y\xi_1}\theta_{zy}} + \frac{\theta_{z\xi_2}\dot{\xi}_2}{\theta_{y\xi_1}\theta_{zy}} &\leq \\ &- (q_z + C) \left(\xi_1 + \frac{y}{\theta_{y\xi_1}} + \frac{z}{\theta_{y\xi_1}\theta_{zy}} + \frac{\theta_{z\xi_2}\xi_2}{\theta_{y\xi_1}\theta_{zy}} \right) \\ &+ (q_z + C) \left(K_1 + \frac{r_1 K_1}{q_y} \frac{1}{4} + \frac{\theta_{z\xi_2}}{\theta_{y\xi_1}\theta_{zy}} K_2 \right) + \frac{r_1 K_1}{4} + \frac{\theta_{z\xi_2} r_2}{\theta_{y\xi_1}\theta_{zy}} \frac{K_2}{4}\end{aligned}$$

and the conclusion follows by the same procedure as above.

Part 2. Attractivity.

Step 1: $\limsup_{t \rightarrow +\infty} \xi_i(t) \leq K_i$, $i = 1, 2$.

Also in this case, this property is a direct consequence of a standard method analogue to the one used in Step 1 of Part 1, having observed that the solution of the initial-value problem

$$\dot{\xi}_i = r_i \xi_i \left(1 - \frac{\xi_i}{K_i} \right), \quad \xi_i^0 \geq 0$$

satisfies $\limsup_{t \rightarrow +\infty} \xi_i(t) = K_i$ if $\xi_i > 0$ and $\limsup_{t \rightarrow +\infty} \xi_i(t) = 0$ if $\xi_i = 0$, for $i = 1, 2$.

Step 2: $\limsup_{t \rightarrow +\infty} \xi_1(t) + \frac{y(t)}{\theta_{y\xi_1}} \leq K_1 + \frac{r_1 K_1}{q_y} \frac{1}{4}$.

For any given $\epsilon > 0$, $\exists T_1 > 0$ such that $\xi_1(t) \leq K_1 + \frac{\epsilon}{2}$ for all $t \geq T_1$, as a consequence of Step 1. Furthermore, by the same rationale as in Step 2 of Part 1, we have

$$\begin{aligned}\xi_1(t) + \frac{y(t)}{\theta_{y\xi_1}} &\leq \\ &\left(K_1 + \frac{r_1 K_1}{q_y} \frac{1}{4} + \frac{\epsilon}{2} \right) - e^{-q_y(t-T_1)} \left[\left(K_1 + \frac{r_1 K_1}{q_y} \frac{1}{4} + \frac{\epsilon}{2} \right) - \left(\xi_1(T_1) + \frac{y(T_1)}{\theta_{y\xi_1}} \right) \right]\end{aligned}$$

Now let $T_2 \geq T_1$ be such that, $\forall t \geq T_2$,

$$e^{-q_y t} \left[\left(K_1 + \frac{r_1 K_1}{q_y} \frac{1}{4} + \frac{\epsilon}{2} \right) - \left(\xi_1(T_1) + \frac{y(T_1)}{\theta_{y\xi_1}} \right) \right] \leq \frac{\epsilon}{2}$$

Then

$$\xi_1(t) + \frac{y(t)}{\theta_{y\xi_1}} \leq K_1 + \frac{r_1}{q_y} \frac{K_1}{4} + \epsilon, \quad \forall t \geq T_2$$

Since $\epsilon > 0$ can be chosen arbitrarily small, the proof is complete.

Step 3: $\limsup_{t \rightarrow +\infty} \xi_1 + \frac{y}{\theta_{y\xi_1}} + \frac{z}{\theta_{y\xi_1}\theta_{zy}} + \frac{\theta_{z\xi_2}\xi_2}{\theta_{y\xi_1}\theta_{zy}} \leq K_1 + \frac{r_1}{q_y} \frac{K_1}{4} + \frac{1}{q_z + C} \left(\frac{r_1 K_1}{4} + \frac{\theta_{z\xi_2}}{\theta_{y\xi_1}\theta_{zy}} \frac{K_2}{4} \right) + \frac{\theta_{z\xi_2}}{\theta_{y\xi_1}\theta_{zy}} K_2$. Also in this case, the proof is easily done applying by the same rationale as in Step 2.

Appendix B. Jacobian matrix. The Jacobian matrix associated to system (3) is:

$$J = \begin{bmatrix} J_{11} & -D_{y\xi_1}\xi_1 & -D_{z\xi_1}\xi_1 & 0 \\ \theta_{y\xi_1}D_{y\xi_1}y & J_{22} & -D_{zy}y & 0 \\ \theta_{z\xi_1}D_{z\xi_1}z & \theta_{zy}D_{zy}z & J_{33} & \theta_{z\xi_2}D_{z\xi_2}z \\ 0 & 0 & -D_{z\xi_2}\xi_2 & J_{44} \end{bmatrix} \quad (22)$$

where

$$\begin{aligned} J_{11} &= r_1 - 2r_1 \frac{\xi_1}{K_1} - D_{y\xi_1}y - D_{z\xi_1}z \\ J_{22} &= \theta_{y\xi_1}D_{y\xi_1}\xi_1 - q_y - D_{zy}z \\ J_{33} &= \sum_{i=1}^2 \theta_{z\xi_i}D_{z\xi_i}\xi_i + \theta_{zy}D_{zy}y - (q_z + C) \\ J_{44} &= r_2 - 2r_2 \frac{\xi_2}{K_2} - D_{z\xi_2}z \end{aligned}$$

Appendix C. Local stability of the non-coexistence equilibrium states.

C.1. Non-coexistence equilibrium states of S^l . In order to evaluate the local stability properties of the equilibrium states associated to S^l , we test the associated Jacobian, obtained from the first three rows/columns of J in (22) by imposing $D_{z\xi_1}, D_{z\xi_2} = 0$.

1. \mathbf{E}_0^l

$$J(E_0^l) = \text{diag}(r_1, -q_y, -(q_z + C))$$

Since by assumption $r_1 > 0$, E_0^l is unstable. The locally asymptotically stable (LAS) subspace is $(0, y, z)$.

2. $\mathbf{E}_{\xi_1}^l$

$J(E_{\xi_1}^l)$ is upper-triangular with

$$\text{diag}(J(E_{\xi_1}^l)) = \left(-r_1, q_y \frac{1 - e_{y\xi_1}}{e_{y\xi_1}}, -(q_z + C) \right)$$

Thus, $E_{\xi_1}^l$ is unstable by the non-triviality assumptions (5). The LAS subspace is $(\xi_1, 0, z)$.

3. $\mathbf{E}_{\xi_1 y}^l$

$$J(E_{\xi_1 y}^l) = \begin{bmatrix} -r_1 e_{y\xi_1} & -\frac{r_1}{g_{y\xi_1}} e_{y\xi_1} & 0 \\ q_y g_{y\xi_1} \frac{1 - e_{y\xi_1}}{e_{y\xi_1}} & 0 & -(q_z + C) \frac{g_{y\xi_1}}{\theta_{zy}} \frac{1 - e_{y\xi_1}}{e_{zy}} \\ 0 & 0 & (q_z + C) \left(g_{y\xi_1} \frac{1 - e_{y\xi_1}}{e_{zy}} - 1 \right) \end{bmatrix}$$

The associated characteristic polynomial is $\mathcal{P}_{\xi_1 y}^l = \mathcal{P}_{\xi_1 y}^{l(1)} \mathcal{P}_{\xi_1 y}^{l(2)}$, where

$$\begin{aligned}\mathcal{P}_{\xi_1 y}^{l(1)} &= -\lambda + J_{33}(E_{\xi_1 y}^l) \\ \mathcal{P}_{\xi_1 y}^{l(2)} &= \lambda^2 - J_{11}(E_{\xi_1 y}^l)\lambda - J_{12}(E_{\xi_1 y}^l)J_{21}(E_{\xi_1 y}^l)\end{aligned}$$

Since all coefficients in the second degree polynomial $\mathcal{P}_{\xi_1 y}^{l(2)}$ have the same sign, its roots are negative. Thus, $E_{\xi_1 y}^l$ is LAS iff the root of $\mathcal{P}_{\xi_1 y}^{l(1)}$ is negative, which is equivalent to

$$D_{zy} < \frac{q_z + C}{\theta_{zy} K_1 g_y \xi_1 (1 - e_{y\xi_1})} \quad (23)$$

C.2. Non-coexistence equilibrium states of \mathcal{S}^o . The Jacobian to be used for evaluating the local stability properties of the considered equilibrium states, in this case, is obtained considering the first three rows/columns of J in (22) and imposing $D_{z\xi_2} = 0$.

1. \mathbf{E}_0^o

$$J(E_0^o) = J(E_0^l)$$

Thus, E_0^o is unstable. The LAS subspace is $(0, y, z)$.

2. $\mathbf{E}_{\xi_1}^o$

$J(E_{\xi_1}^o)$ is upper-triangular with

$$\text{diag}(J(E_{\xi_1}^o)) = \left(-r_1, q_y \frac{1 - e_{y\xi_1}}{e_{y\xi_1}}, (q_z + C) \frac{1 - e_{z\xi_1}}{e_{z\xi_1}} \right)$$

Thus, $E_{\xi_1}^o$ is unstable by the non-triviality assumptions (5). The LAS subspace is $(\xi_1, 0, 0)$.

3. $\mathbf{E}_{\xi_1 y}^o$

$$J(E_{\xi_1 y}^o) = \begin{bmatrix} -r_1 e_{y\xi_1} & -\frac{r_1}{g_y \xi_1} e_{y\xi_1} & -\frac{r_1}{g_z \xi_1} e_{y\xi_1} \\ q_y g_y \xi_1 \frac{1 - e_{y\xi_1}}{e_{y\xi_1}} & 0 & -(q_z + C) \frac{g_y \xi_1}{\theta_{zy}} \frac{1 - e_{y\xi_1}}{e_{zy}} \\ 0 & 0 & (q_z + C) \left(g_y \xi_1 \frac{1 - e_{y\xi_1}}{e_{zy}} - 1 + \frac{e_{y\xi_1}}{e_{z\xi_1}} \right) \end{bmatrix}$$

By the same rationale as in the case of $E_{\xi_1 y}^l$, we can write the associated characteristic polynomial as the product $\mathcal{P}_{\xi_1 y}^o = \mathcal{P}_{\xi_1 y}^{o(1)} \mathcal{P}_{\xi_1 y}^{o(2)}$, where

$$\begin{aligned}\mathcal{P}_{\xi_1 y}^{o(1)} &= -\lambda + J_{33}(E_{\xi_1 y}^o) \\ \mathcal{P}_{\xi_1 y}^{o(2)} &= \lambda^2 - J_{11}(E_{\xi_1 y}^o)\lambda - J_{12}(E_{\xi_1 y}^o)J_{21}(E_{\xi_1 y}^o) = \mathcal{P}_{\xi_1 y}^{l(2)}\end{aligned}$$

Consequently, from the definition of $\mathcal{P}_{\xi_1 y}^{o(1)}$, the following condition is necessary and sufficient for the considered equilibrium to be LAS:

$$D_{zy} < \frac{q_z + C}{\theta_{zy} K_1 g_y \xi_1 (1 - e_{y\xi_1})} \left(1 - \frac{e_{y\xi_1}}{e_{z\xi_1}} \right)$$

4. $\mathbf{E}_{\xi_1 z}^o$

$$J(E_{\xi_1 z}^o) = \begin{bmatrix} -r_1 e_{z\xi_1} & & -\frac{r_1}{g_y \xi_1} e_{z\xi_1} & & -\frac{r_1}{g_z \xi_1} e_{z\xi_1} \\ 0 & q_y \left(\frac{e_{z\xi_1}}{e_{y\xi_1}} - 1 \right) & - (q_z + C) \frac{g_z \xi_1}{\theta_{zy}} \frac{1 - e_{z\xi_1}}{e_{zy}} & & 0 \\ (q_z + C) g_z \xi_1 \frac{1 - e_{z\xi_1}}{e_{z\xi_1}} & & (q_z + C) g_z \xi_1 \frac{1 - e_{z\xi_1}}{e_{zy}} & & 0 \end{bmatrix}$$

In this case, the associated characteristic polynomial is $\mathcal{P}_{\xi_1 z}^o = \mathcal{P}_{\xi_1 z}^{o(1)} \mathcal{P}_{\xi_1 z}^{o(2)}$, where

$$\begin{aligned}\mathcal{P}_{\xi_1 z}^{o(1)} &= -\lambda + J_{22}(E_{\xi_1 z}^o) \\ \mathcal{P}_{\xi_1 z}^{o(2)} &= \lambda^2 - J_{11}(E_{\xi_1 z}^o)\lambda - J_{13}(E_{\xi_1 z}^o)J_{31}(E_{\xi_1 z}^o)\end{aligned}$$

Since all terms in $\mathcal{P}_{\xi_1 z}^{o(2)}$ have the same sign, its roots are negative. Thus, in order to guarantee that $E_{\xi_1 z}^o$ is LAS, we have to impose that the root of $\mathcal{P}_{\xi_1 z}^{o(1)}$ is negative, which is true iff

$$D_{zy} > \frac{q_y}{K_1 g_{z\xi_1} (1 - e_{z\xi_1})} \left(\frac{e_{z\xi_1}}{e_{y\xi_1}} - 1 \right)$$

C.3. Non-coexistence equilibrium states of \mathcal{S}^p . In this case, the Jacobian is obtained from the general Jacobian matrix (22) by assuming $D_{z\xi_1} = 0$.

1. \mathbf{E}_0^p

$$J(E_0^p) = \text{diag}(r_1, -q_y, -(q_z + C), r_2)$$

Since $r_1, r_2 > 0$, E_0^p is unstable. The LAS subspace is $(0, y, z, 0)$.

2. $\mathbf{E}_{\xi_1}^p$

$J(E_{\xi_1}^p)$ is upper-triangular with

$$\text{diag}(J(E_{\xi_1}^p)) = \left(-r_1, q_y \frac{1 - e_{y\xi_1}}{e_{y\xi_1}}, -(q_z + C), r_2 \right)$$

Thus, $E_{\xi_1}^p$ is unstable. The LAS subspace is $(\xi_1, 0, z, 0)$.

3. $\mathbf{E}_{\xi_2}^p$

$J(E_{\xi_2}^p)$ is lower-triangular with

$$\text{diag}(J(E_{\xi_2}^p)) = \left(r_1, -q_y, (q_z + C) \frac{1 - e_{z\xi_2}}{e_{z\xi_2}}, -r_2 \right)$$

Thus, $E_{\xi_2}^p$ is unstable. The LAS subspace is $(0, y, 0, \xi_2)$.

4. $\mathbf{E}_{\xi_1 \xi_2}^p$

The eigenvalues of the Jacobian matrix $J(E_{\xi_1 \xi_2}^p)$ coincide with its diagonal entries, which are

$$\text{diag}(J(E_{\xi_1 \xi_2}^p)) = \left(-r_1, q_y \frac{1 - e_{y\xi_1}}{e_{y\xi_1}}, (q_z + C) \frac{1 - e_{z\xi_2}}{e_{z\xi_2}}, -r_2 \right)$$

It results that this equilibrium is unstable. The LAS subspace is $(\xi_1, 0, 0, \xi_2)$.

5. $\mathbf{E}_{\xi_1 y}^p$

$$J(E_{\xi_1 y}^p) = \begin{bmatrix} -r_1 e_{y\xi_1} & -\frac{r_1}{g_{y\xi_1}} e_{y\xi_1} & 0 & 0 \\ q_y g_{y\xi_1} \frac{1 - e_{y\xi_1}}{e_{y\xi_1}} & 0 & -(q_z + C) \frac{g_{y\xi_1}}{\theta_{zy}} \frac{1 - e_{y\xi_1}}{e_{zy}} & 0 \\ 0 & 0 & (q_z + C) \left(g_{y\xi_1} \frac{1 - e_{y\xi_1}}{e_{zy}} - 1 \right) & 0 \\ 0 & 0 & 0 & r_2 \end{bmatrix}$$

The associated characteristic polynomial is $\mathcal{P}_{\xi_1 y}^p = \mathcal{P}_{\xi_1 y}^{p(1)} \mathcal{P}_{\xi_1 y}^{p(2)} \mathcal{P}_{\xi_1 y}^{p(3)}$, where

$$\mathcal{P}_{\xi_1 y}^{p(1)} = \lambda^2 - J_{11}(E_{\xi_1 y}^p)\lambda - J_{12}(E_{\xi_1 y}^p)J_{21}(E_{\xi_1 y}^p)$$

$$\mathcal{P}_{\xi_1 y}^{p(2)} = -\lambda + J_{33}(E_{\xi_1 y}^p)$$

$$\mathcal{P}_{\xi_1 y}^{p(3)} = -\lambda + J_{44}(E_{\xi_1 y}^p)$$

The root of $\mathcal{P}_{\xi_1 y}^{p(3)}$ is positive. Thus, the considered equilibrium is unstable. Moreover, $\mathcal{P}_{\xi_1 y}^{p(1)}$ has negative roots, while $\mathcal{P}_{\xi_1 y}^{p(2)}$ has negative roots *iff* condition (23) holds. Thus, the LAS subspace is $(\xi_1, y, z, 0)$ if (23) holds and $(\xi_1, y, 0, 0)$ otherwise.

6. $\mathbf{E}_{z\xi_2}^P$

$$J(E_{z\xi_2}^P) = \begin{bmatrix} r_1 & 0 & 0 & 0 \\ 0 & -q_y - (q_z + C) \frac{K_2 g_{z\xi_2}}{K_1 \theta_{zy}} \frac{1-e_{z\xi_2}}{e_{zy}} & 0 & 0 \\ 0 & (q_z + C) \frac{K_2}{K_1} g_{z\xi_2} \frac{1-e_{z\xi_2}}{e_{zy}} & 0 & \theta_{z\xi_2} r_2 (1 - e_{z\xi_2}) \\ 0 & 0 & -\frac{r_2}{g_{z\xi_2}} e_{z\xi_2} & -r_2 e_{z\xi_2} \end{bmatrix}$$

The associated characteristic polynomial is $\mathcal{P}_{z\xi_2}^p = \mathcal{P}_{z\xi_2}^{p(1)} \mathcal{P}_{z\xi_2}^{p(2)} \mathcal{P}_{z\xi_2}^{p(3)}$, where

$$\begin{aligned} \mathcal{P}_{z\xi_2}^{p(1)} &= -\lambda + J_{11}(E_{z\xi_2}^P) \\ \mathcal{P}_{z\xi_2}^{p(2)} &= -\lambda + J_{22}(E_{z\xi_2}^P) \\ \mathcal{P}_{z\xi_2}^{p(3)} &= \lambda^2 - J_{44}(E_{z\xi_2}^P)\lambda - J_{34}(E_{z\xi_2}^P)J_{43}(E_{z\xi_2}^P) \end{aligned}$$

The root of $\mathcal{P}_{\xi_1 y}^{p(1)}$ is positive. Thus, the considered equilibrium is unstable. Moreover, $\mathcal{P}_{\xi_1 y}^{p(2)}$ and $\mathcal{P}_{\xi_1 y}^{p(3)}$ have negative roots, which implies that the LAS subspace of this equilibrium is $(0, y, z, \xi_2)$.

7. $\mathbf{E}_{\xi_1 y \xi_2}^P$

$$J(E_{\xi_1 y \xi_2}^P) = \begin{bmatrix} -r_1 e_{y\xi_1} & -\frac{r_1}{g_{y\xi_1}} e_{y\xi_1} & 0 & 0 \\ q_y g_{y\xi_1} \frac{1-e_{y\xi_1}}{e_{y\xi_1}} & 0 & -(q_z + C) \frac{g_{y\xi_1}}{\theta_{zy}} \frac{1-e_{y\xi_1}}{e_{zy}} & 0 \\ 0 & 0 & (q_z + C) \left(\frac{1}{e_{z\xi_2}} - 1 + g_{y\xi_1} \frac{1-e_{y\xi_1}}{e_{zy}} \right) & 0 \\ 0 & 0 & -\frac{r_2}{g_{z\xi_2}} & -r_2 \end{bmatrix}$$

The associated characteristic polynomial is $\mathcal{P}_{\xi_1 y \xi_2}^p = \mathcal{P}_{\xi_1 y \xi_2}^{p(1)} \mathcal{P}_{\xi_1 y \xi_2}^{p(2)} \mathcal{P}_{\xi_1 y \xi_2}^{p(3)}$, where

$$\begin{aligned} \mathcal{P}_{\xi_1 y \xi_2}^{p(1)} &= \lambda^2 - J_{11}(E_{z\xi_2}^P)\lambda - J_{12}(E_{z\xi_2}^P)J_{21}(E_{z\xi_2}^P) \\ \mathcal{P}_{\xi_1 y \xi_2}^{p(2)} &= -\lambda + J_{33}(E_{z\xi_2}^P) \\ \mathcal{P}_{\xi_1 y \xi_2}^{p(3)} &= -\lambda + J_{44}(E_{z\xi_2}^P) \end{aligned}$$

The roots of $\mathcal{P}_{\xi_1 y \xi_2}^{p(1)}$ and $\mathcal{P}_{\xi_1 y \xi_2}^{p(3)}$ are negative, while the root of $\mathcal{P}_{\xi_1 y \xi_2}^{p(2)}$ is negative *iff*

$$D_{zy} < \frac{q_z + C}{g_{y\xi_1}(1 - e_{y\xi_1})\theta_{zy}K_1} \left(1 - \frac{1}{e_{z\xi_2}} \right)$$

Since $1 - \frac{1}{e_{z\xi_2}} < 0$ and $D_{zy} > 0$ by definition, the latter condition is never verified and the equilibrium is unstable. The LAS subspace is $(\xi_1, y, 0, \xi_2)$.

8. $\mathbf{E}_{\xi_1 z \xi_2}^P$

$$J(E_{\xi_1 z \xi_2}^P) = \begin{bmatrix} -r_1 & -\frac{r_1}{g_{y\xi_1}} & 0 & 0 \\ 0 & q_y \frac{1-e_{y\xi_1}}{e_{y\xi_1}} - (q_z + C) \frac{K_2 g_{z\xi_2}}{K_1 \theta_{zy}} \frac{1-e_{z\xi_2}}{e_{zy}} & 0 & 0 \\ 0 & (q_z + C) \frac{K_2}{K_1} g_{z\xi_2} \frac{1-e_{z\xi_2}}{e_{zy}} & 0 & (q_z + C) g_{z\xi_2} \frac{1-e_{z\xi_2}}{e_{z\xi_2}} \\ 0 & 0 & -\frac{r_2}{g_{z\xi_2}} e_{z\xi_2} & -r_2 e_{z\xi_2} \end{bmatrix}$$

The associated characteristic polynomial is $\mathcal{P}_{\xi_1 z \xi_2}^p = \mathcal{P}_{\xi_1 z \xi_2}^{p(1)} \mathcal{P}_{\xi_1 z \xi_2}^{p(2)} \mathcal{P}_{\xi_1 z \xi_2}^{p(3)}$, where

$$\begin{aligned}\mathcal{P}_{\xi_1 z \xi_2}^{p(1)} &= -\lambda + J_{11}(E_{\xi_1 z \xi_2}^p) \\ \mathcal{P}_{\xi_1 z \xi_2}^{p(2)} &= -\lambda + J_{22}(E_{\xi_1 z \xi_2}^p) \\ \mathcal{P}_{\xi_1 z \xi_2}^{p(3)} &= \lambda^2 - J_{44}(E_{\xi_1 z \xi_2}^p)\lambda - J_{34}(E_{\xi_1 z \xi_2}^p)J_{43}(E_{\xi_1 z \xi_2}^p)\end{aligned}$$

The roots of $\mathcal{P}_{\xi_1 z \xi_2}^{p(1)}$ and $\mathcal{P}_{\xi_1 z \xi_2}^{p(3)}$ are negative, while the root of $\mathcal{P}_{\xi_1 z \xi_2}^{p(2)}$ is negative iff

$$D_{zy} > \frac{q_y}{K_2 g_{z \xi_2} (1 - e_{z \xi_2})} \frac{1 - e_{y \xi_1}}{e_{y \xi_1}}$$

REFERENCES

- [1] N. C. Apreutesei, [Necessary optimality conditions for a Lotka-Volterra three species system](#), *Math. Model. Nat. Phenom.*, **1** (2006), 120–135.
- [2] N. C. Apreutesei, [An optimal control problem for a prey-predator system with a general functional response](#), *Appl. Math. Lett.*, **22** (2009), 1062–1065.
- [3] C. D. Becker and E. Ostrom, Human ecology and resource sustainability: The importance of institutional diversity, *Annual Review of Ecology and Systematics*, **26** (1995), 113–133.
- [4] J. C. Castilla, [Coastal marine communities: Trends and perspectives from human-exclusion experiments](#), *Trends in Ecology & Evolution*, **14** (1999), 280–283.
- [5] K. S. Chaudhuri, [A bioeconomic model of harvesting a multispecies fishery](#), *Ecological Modelling*, **32** (1986), 267–279.
- [6] T. Christiaans, T. Eichner and R. Pethig, [Optimal pest control in agriculture](#), *J. Econom. Dynam. Control*, **31** (2007), 3965–3985.
- [7] N. J. Cossins and M. Upton, [The Borana pastoral system of Southern Ethiopia](#), *Agricultural Systems*, **25** (1987), 199–218.
- [8] T. Das, R. N. Mukherjee and K. S. Chaudhuri, [Harvesting of a prey-predator fishery in the presence of toxicity](#), *Appl. Math. Model.*, **33** (2009), 2282–2292.
- [9] S. Desta and D. L. Coppock, [Pastoralism under pressure: Tracking system change in Southern Ethiopia](#), *Human Ecology*, **32** (2004), 465–486.
- [10] A. El-Gohary and M. T. Yassen, [Optimal control and synchronization of Lotka-Volterra model](#), *Chaos, Solitons and Fractals*, **12** (2001), 2087–2093.
- [11] B. D. Fath, [Distributed control in ecological networks](#), *Ecological Modelling*, **179** (2004), 235–245.
- [12] C. Feinstein and D. Luenberger, [Analysis of the asymptotic behavior of optimal control trajectories: The implicit programming problem](#), *SIAM J. Control Optim.*, **19** (1981), 561–585.
- [13] G. Gilioli and J. Baumgärtner, Parameter estimation for a disease transmission model on the population dynamics of Africa’s Brown Ear Tick (*Rhipicephalus appendiculatus*, Acari: Ixodidae) and cattle infected by East Coast Fever, *Bollettino di Zoologia Agraria e bachicoltura, Serie II*, **41** (2009), 21–40.
- [14] A. P. Gutierrez and U. Regev, The bioeconomics of tri-trophic systems: Applications to invasive species, *Ecological Economics*, **52** (2005), 383–396.
- [15] C. S. Holling, [The functional response of invertebrate predators to prey density](#), in *Memoirs of the Entomological Society of Canada*, Vol. 48, Ottawa, Canada, 1966.
- [16] V. S. Ivlev, *Experimental Ecology of the Feeding of Fishes*, Yale University Press, New Haven, Connecticut, 1961.
- [17] T. K. Kar and B. Ghosh, [Sustainability and optimal control of an exploited prey predator system through provision of alternative food to predator](#), *Biosystems*, **109** (2012), 220–232.
- [18] V. Krivan and S. Diehl, Adaptive omnivory and species coexistence in tri-trophic food webs, *Theoretical Population Biology*, **67** (2005), 85–99.
- [19] V. Krivan and J. Eisner, Optimal foraging and predator-prey dynamics III, *Theoretical Population Biology*, **63** (2003), 269–279.
- [20] L. J. Lambourne, M. S. Dicko, P. Semenyé and M. H. Butterworth, Animal nutrition in pastoral system research in sub-Saharan Africa, in *Proceedings of the ILCA/IDRC Workshop held at ILCA*, Addis Ababa, Ethiopia, 1983.

- [21] R. Lande, S. Engen and B.-E. Saether, Optimal harvesting, economic discounting and extinction risk in fluctuating populations, *Nature*, **11** (1994), 88–90.
- [22] A. Leung and S. Stojanovic, Optimal control for elliptic Volterra-Lotka type equations, *J. Math. Anal. Appl.*, **173** (1993), 603–619.
- [23] D. Ludwig, R. Hilborn and C. Walters, Uncertainty, resource exploitation, and conservation: Lessons from history, *Science*, **260** (1993), 17–36.
- [24] L. Mariani and S. Parisi, Simulation of grazed grassland productivity in Ethiopian Highlands, in *Sustainable agro-pastoral systems: Concepts, approaches and tools*, CNR-IMATI, Milan, Italy, March 27, 2012. Available from: <http://www.mi.imati.cnr.it/~sara/biodiversita/paginaweb.html>.
- [25] T. Nakazawa and N. Yamamura, Community structure and stability analysis for intraguild interactions among host, parasitoid, and predator, *Population Ecology*, **48** (2006), 139–149.
- [26] T. Namba, K. Tanabe and N. Maeda, Omnivory and stability of food webs, *Ecological Complexity*, **5** (2008), 73–85.
- [27] National Academy of Sciences, Tef, in *Lost Crops of Africa: Vol. I: Grains*, National Academies Press, Washington, 1996.
- [28] E. Neumayer, The human development index and sustainability: A constructive proposal, *Ecological Economics*, **39** (2001), 101–114.
- [29] M. M. Nyangito, N. K. R. Musimba and D. M. Nyariki, Range use and dynamics in the agropastoral system of southeastern Kenya, *African Journal of Environmental Science and Technology*, **2** (2008), 222–230.
- [30] T. Pradhan and K. S. Chaudhuri, A dynamic reaction model of a two-species fishery with taxation as a control instrument: A capital theoretic analysis, *Ecological Modelling*, **121** (1999), 1–16.
- [31] M. Rafikov, J. M. Balthazar and H. F. von Bremen, Mathematical modeling and control of population systems: Applications in biological pest control, *Applied Mathematics and Computation*, **200** (2008), 557–573.
- [32] U. Regev, A. P. Gutierrez, S. J. Schreiber and D. Zilbermann, Biological and economic foundations of renewable resource exploitation, *Ecological Economics*, **26** (1998), 227–242.
- [33] R. S. Reid, S. Serneels, M. Nyabenge and J. Hanson, The changing face of pastoral systems in grassland dominated ecosystem of East Africa, in *Grassland of the World*, 2005, 19–65.
- [34] Global Health Observatory Data Repository, 2012. Available from: <http://apps.who.int/gho/data/>.
- [35] S. Sager, H. G. Bock, M. Diehl, G. Reinelt and J. P. Schlöder, Numerical methods for optimal control with binary control functions applied to a Lotka-Volterra type fishing problem, in *Recent Advances in Optimization* (ed. Alberto Seeger), Lecture Notes in Economics and Mathematical Systems, Vol. 563, Springer, Berlin, 2006, 269–289.
- [36] Y. Shastri and U. Diwekar, Sustainable ecosystem management using optimal control theory. I. Deterministic Systems, *J. Theoret. Biol.*, **241** (2006), 506–521.
- [37] ———, Sustainable ecosystem management using optimal control theory. 2. Stochastic Systems, *J. Theoret. Biol.*, **241** (2006), 522–532.
- [38] A. Sikder and A. B. Roy, Persistence of a four species food chain with full omnivory, *Biosystems*, **31** (1993), 39–47.
- [39] X. Song and L. Chen, Optimal harvesting and stability for a two-species competitive system with stage structure, *Math. Biosci.*, **170** (2001), 173–186.
- [40] P. D. N. Srinivasu, B. S. R. V. Prasad and M. Venkatesulu, Biological control through provision of additional food to predators: A theoretical study, *Theoretical Population Biology*, **72** (2007), 111–120.
- [41] Yu. M. Svirezhev and D. O. Logofet, *Stability of Biological Communities*, “Mir”, Moscow, 1983.
- [42] F. M. Wilkes, *Capital Budgeting Techniques*, John Wiley & Sons, New York, 1977.

Received November 17, 2012; Accepted August 03, 2013.

E-mail address: luca.galbusera@jrc.ec.europa.eu

E-mail address: sara.pasquali@mi.imati.cnr.it

E-mail address: gianni.gilioli@med.unibs.it