

Multifunction Portals for Train Monitoring: Recent Advances and Innovative Optoelectronic Instrumentation

Luca Fumagalli¹, Paolo Tomassini¹, Marco Zanatta¹, Giorgio Libretti¹,
Marco Trebeschi¹, Giovanna Sansoni² and Franco Docchio²

¹*Q-Tech Srl, Rezzato (BS),*

²*Laboratory of Optoelectronics, University of Brescia, Brescia,
Italy*

1. Introduction

Railway transportation is the ideal infrastructure for remote control and high-tech monitoring solutions. After the completion of the remote control operation of the Italian railway system, in fact, the need arose of monitoring equipment that could detect the status of the trains travelling along the tracks, and could transfer the status information to the control centres, for a prompt response in case abnormalities were reported (train blocking, signalling). This is of primary importance for Italy, full of mountains and therefore of tunnels crossing them. The need to control train integrity well before the tunnel input is motivated by the need of arresting the convoy on time in presence of (i) misalignments of carriage loads, and (ii) abnormal temperature rises in any part of the engine or of the carriage. This need has motivated the national railway Company *Ferrovie dello Stato* to launch a project aimed at installing a number of train monitoring multifunction portals at suitable distances from the tunnel entrances. The concept of multifunction portal is related to the presence of a number of concurrent sensors, each performing a separate task, and integrated in a common software platform that elaborates the sensor information and issues the train status information and possible alarms.

The first monitoring portal put in exercise in the middle 2000's is the portal of Exilles, on the Turin-Modane Railway line. This portal was implemented after the tragic Montblanc tunnel motorway accident. The portal was equipped with thermal cameras to monitor temperature abnormalities. In 2005 the Company launched a first experimental multifunction portal, that was supposed to combine 3D shape, thermal distribution and visual profile, to carriage length and type information. The portal had to be located to monitor one of the tracks at the entrance of the Station of Rastignano, along the Firenze - Prato (Tuscany) Railway line. Sirti S.p.A. was entrusted with the realization of the portal. A partnership was then formed, which included our company, Q-Tech s.r.l., and the companion Laboratory of Optoelectronics of the University of Brescia. Q-Tech s.r.l. was in charge of the development of the 3D-profile, visual and thermal sensors for the monitoring portal, together with all the software for the control and synchronization of the sensors and the setting of the alarms to be sent along the

line. To this aim, it collaborated with the parent Laboratory of Optoelectronics, which focused on the development of the software for data acquisition, elaboration and alarm generation. The portal was set in operation in 2007.

In the same year a second project was launched by the Ferrovie dello Stato, for the development of two second-generation, two-track monitoring, multifunction portals, to be installed at the two sides of a three-tunnel series on the high-velocity Rome-Formia-Neaples Railway line. One of the two portals has been assigned to the Sirti-Q-Tech partnership (the one Located at Minturno, south side of the monitored line), the other to Ansaldo S.p.A. (located in Sezze Romano, north side). This was a more ambitious project, since the high-velocity nature of the line required more stringent performance specifications of the sensors and the data collection and elaboration procedure. Both assignees completed their work in 2010, and the two portals are now operative.

The two portals developed by Sirti and Q-Tech are significantly different, due to the above mentioned requirements. The major difference is in the 3D shape sensors which, in the first portal, have been purchased from a German Research Institute, and in the second have been completely in-house designed, developed and tested by Q-Tech. This is due to the fact that the previous sensors had a number of drawbacks that were inherently due to the measurement principle (phase difference telemetry). Q-Tech's solution for the second portal is based on pulsed time-of-flight telemetry, which allows a better signal-to-noise ratio in the visible, and results in much better defined 3D profiles. The availability of high repetition rate lasers allowed, in addition, to obtain four 3D shape measurement sensors with only one laser source, multiplexed in emission and detection, and making use of fibre optics to reach the scanning mirrors. This resulted in much lower sensor costs, better maintainability, and safety of operation.

This chapter is devoted to the description of the work done by Q-Tech in the Sirti/Q-Tech partnership, with reference to (i) the optoelectronic instrumentation in multifunction portals, and (ii) the innovative optoelectronic 3D scanner based on time-of-flight telemetry, for the high speed monitoring of the train profile in three dimensions and with a multiplexed geometry.

2. Optoelectronic instrumentation in multifunction portals

2.1 Architecture of a portal

In a Railway Multifunction Portal a number of elaboration systems acquire, combine and elaborate data coming from a number of sensors, and produce suitable alarms in case of non-conformities of the train. A photograph of a Railway Multifunction Portal is shown in Fig. 1.

Fig. 2 shows the overall system architecture of a portal. The project and the development of the systems shown on the left side of this figure is the core of Q-Tech know-how; these systems will be described in the next paragraphs of this chapter. In particular we recognize:

- 3D shape monitoring systems, making use of the innovative telemeters described in the next section: they acquire the train profiles and compare them to reference profiles, issuing alarms when the measured profiles exceed the reference ones;

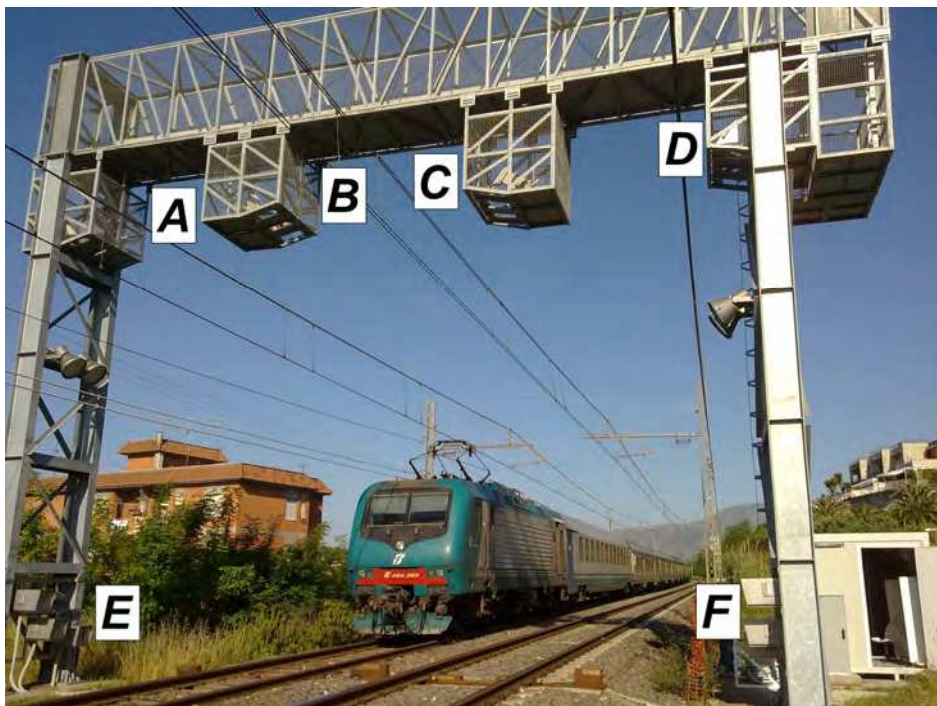

Fig. 1. Picture of a train-monitoring Portal. Sensors in positions A and C monitor the left track, whereas sensors in positions B and D monitor the right track; sensors in positions E and F perform the monitoring of the lower part of the train.

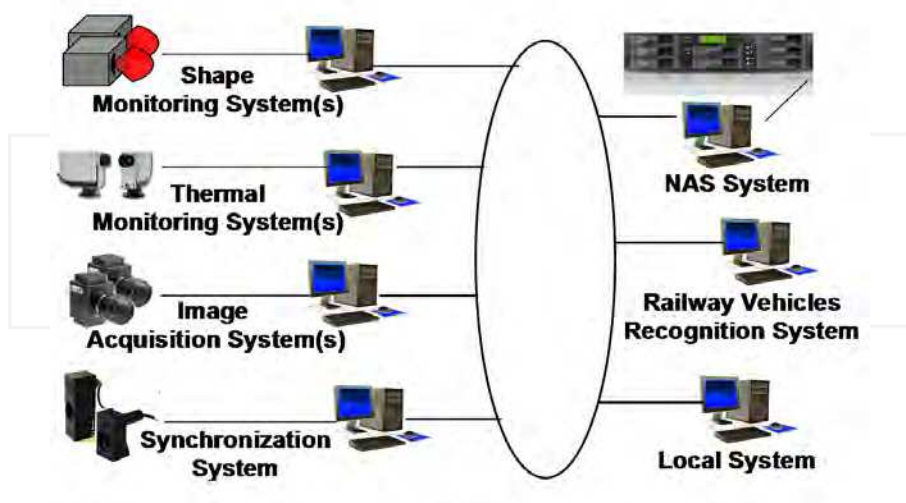

Fig. 2. Overall architecture of a Railway Multifunction Portal

- thermal monitoring systems: they acquire the thermal maps of the trains and compare them to nominal operating temperatures, which are different according to the part of the carriage considered; the aim is to issue alarms in case of risk of fire caused by abnormally high temperatures;
- image acquisition systems, providing visual images of the train by means of high-speed linear cameras;
- a synchronization system: its purpose is to set a reference to all the data acquired by the other systems to the actual configuration of the train in transit; this is achieved by detecting: (i) the transit of the axles under the portal as detected by suitable sensors, (ii) the discontinuities between different carriages, and (iii) the presence of a train on the opposite track.

These systems interact with the high-level systems (not developed by Q-Tech) as depicted in the right part of Fig. 2:

- a NAS system is a high-capability storage unit intended to save the data resulting from the elaboration of all measurements;
- a railway vehicle recognition system, which allows the identification of the train by recognizing the number and the type of carriages that compose it;
- a local system, hosting the user interface which allows the operator to view data and alarms and to configure the parameters for each system.

The measurement and elaboration units are industrial PCs contained in an isolated shelter situated in proximity to the portal (see the right side of Fig. 1); the elaboration units are connected to their measuring sensors.

Issues concerning fast data elaboration and data handling were particularly critical in this project, given the huge amount of data acquired from all the sensors: in fact the systems are required to monitor trains running up to 300 Km/h, and any alarm must be raised within 90 seconds after the end of the transit.

2.2 The image acquisition system

The train image acquisition is performed by using line-scan cameras operating in the visible. Their purpose is to visualise the train in transit. More systems can be installed on a Portal, in order to acquire both the upper part of the trains (e.g. positions A, B, C, D in Fig. 1) and their lower part (e.g. positions E, F in Fig. 1). The frequency of the scan is calculated according to the train speed, to keep the spacing (in mm) between two successive scans to a constant value.

Two illuminators, driven by crepuscular sensors, start operating at sunset. The exposure time is set according to the track illumination conditions in order to avoid over- and underexposures.

Fig. 3 (a) and (b) show details of the visual images of the left side of a train in transit, acquired by the upper and the lower image acquisition system respectively.

2.3 The thermal monitoring system

Thermal monitoring is performed by using commercial pyroelectric line cameras. More systems can be installed on a Portal, in order to acquire both the upper part of the trains (e.g. positions A, B, C, D in Fig. 1) and their lower part (e.g. positions E, F in Fig. 1). In particular,

to monitor the lower part of the train, the cameras can be installed either on both sides of the portal, or within a hollow crosspiece situated under the track.

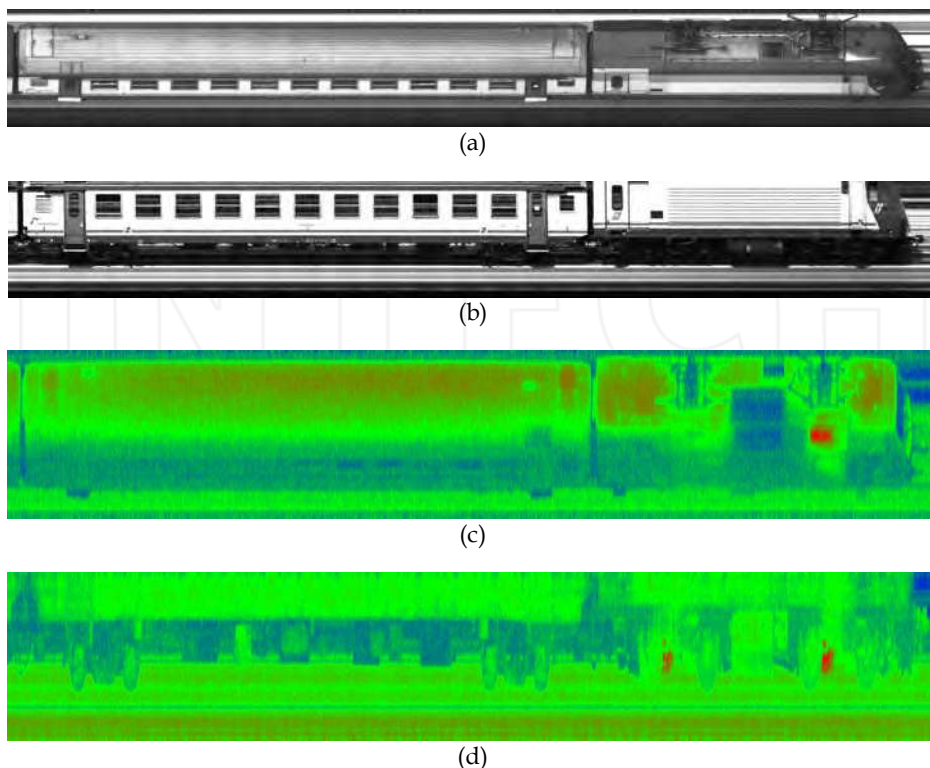

Fig. 3. Sample acquisition of the left side of a train (only the locomotive and the first passenger car are shown): (a) visual image, upper part; (b) visual image, lower part; (c) thermal map, upper part; (d) thermal map, lower part.

Each sensor acquires a thermal map of the train in transit; starting from the acquired data, up to four different thermal inspections can be performed:

1. "Fire on board" inspection: comparison with a maximum reference temperature;
2. "Maximum carriage temperature" inspection: comparison with a reference temperature depending on the type of carriage;
3. "Regions of Interest (ROI) grid inspection": each railway vehicle is split into a grid of rectangular regions: each region is characterized by a specific reference temperature; this inspection has the purpose to detect over-threshold situations in different parts of each carriage, each characterized by its own operating temperature and alarm threshold;
4. "Axle boxes" inspection: the position of each axle box is detected, to launch a warning in case of overheat.

Fig. 3 (c) and (d) show a detail of the thermal maps of the left side of a train in transit, acquired by the upper and the lower thermal acquisition system respectively.

Fig. 4 shows the thermal acquisition of the lower part of a locomotive (left side) and a passenger car (right side) of a train at the speed of 153 Km/h: the carriage wheels are evident in the map as circles. The lower part of Fig. 4 shows a detail of the corresponding visual image of the wheels acquired by the lower image acquisition system. The situation of the four axles of the passenger car (right side of Fig. 4) is normal, whereas the green-coloured portions in correspondence to the four axles of the locomotive (left side of the Figure) indicate clearly that the wheels are hotter, presumably because the carriage brakes are active.

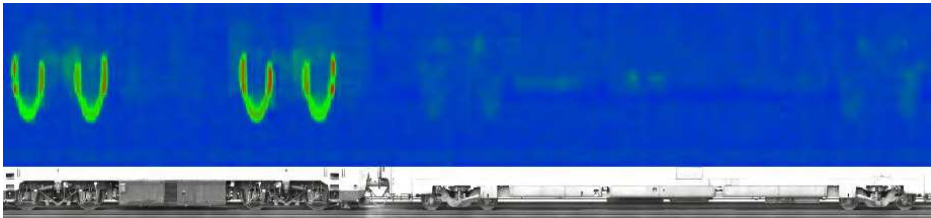

Fig. 4. Example of thermal acquisition of the lower part of a train (thermal map, upper, and visual image, lower).

2.4 The synchronization system

The multifunction portal is based on the cooperation among different acquisition and elaboration units (Fig. 5), which operate separately but must (i) refer their data to a common time base, and (ii) trace the elaboration flux and outline potential malfunction situations. In fact, the purpose of each system is to acquire all the data pertaining to a transit from all the portal sensors, setting its own internal resolution and synchronizing its information through control signals that allow the establishment of a common time base for all the systems. Moreover, each system must provide the data according to suitable formats, useful for the analysis of the convoy at the local level (verification of the presence of alarms) and at the remote level (visualization of the overall train situation).

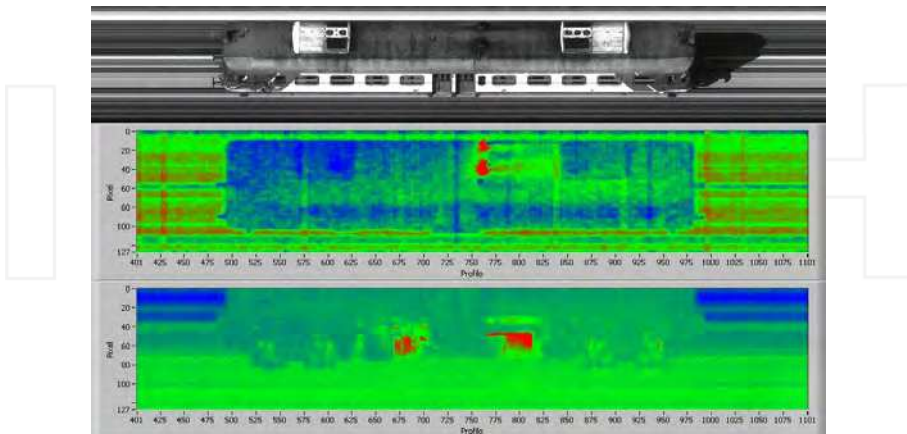

Fig. 5. Example of the acquisition of the left side of a locomotive concurrently performed by the upper image acquisition system, and the upper and lower thermal monitoring systems.

The common time base to the units is provided by a synchronization system, developed by Q-Tech; this system performs the acquisition and the elaboration of signals coming from sensors that detect the transit of each wheel (the so-called “pedals”) at known distances. Moreover the synchronization system makes use of a discontinuity sensor to detect the instant of beginning and end of each carriage. The synchronization system has also the task of handling the presence of two trains concurrently under the portal, as shown in Fig. 6.



Fig. 6. Example of a concurrent transit.

3. New optoelectronic developments: The 400-kHz distributed time-of-flight telemeter

After the first portal in Rastignano it was decided to carry out an in-house development of a time-of-flight distributed telemeter unit, also due to the fact that four scanning heads were required, to scan two railway tracks. This distributed telemeter uses a single transmitter/detector unit. This unit is well shielded from the trains and from the environment inside the control shelter of the portal, and feeds, in a multiplexed way, the required number of scanning stations through transmission/detection optical fibre pairs.

3.1 Description of the telemeter

The system operates at 400 kHz, with an extended dynamic range to solve the problem of measuring distance of targets in a variable range of distances and angles. The use of a sub-nanosecond risetime pulse allows to obtain accuracies well below the centimeter at distances of some meters. The use of fibre pairs for transmission and detection allows to place the remote measuring stations at distances of 50-100 m from the main unit.

Fig. 7 shows the overall architecture of the system.

The distributed telemeter is composed of four measuring stations, namely 1l, 1r, 2l and 2r. The architecture of the system is rather flexible, to adapt to different measuring requirements (higher number of measuring stations, different timing, etc.). A single control unit contains the transmitter laser source with all the optical components for the beam shaping, and the receiver detectors and electronics for the measurement of the optical signals from the targets. Each remote station is connected to the central control unit by means of (i) a transmitter fiber carrying the signal from the transmitter, (ii) a receiver fiber carrying the signal from the target, and (iii) an adequate number of control signals.

Fig. 8 shows the details of the transmitter and receiver optical units of the telemeter setup.

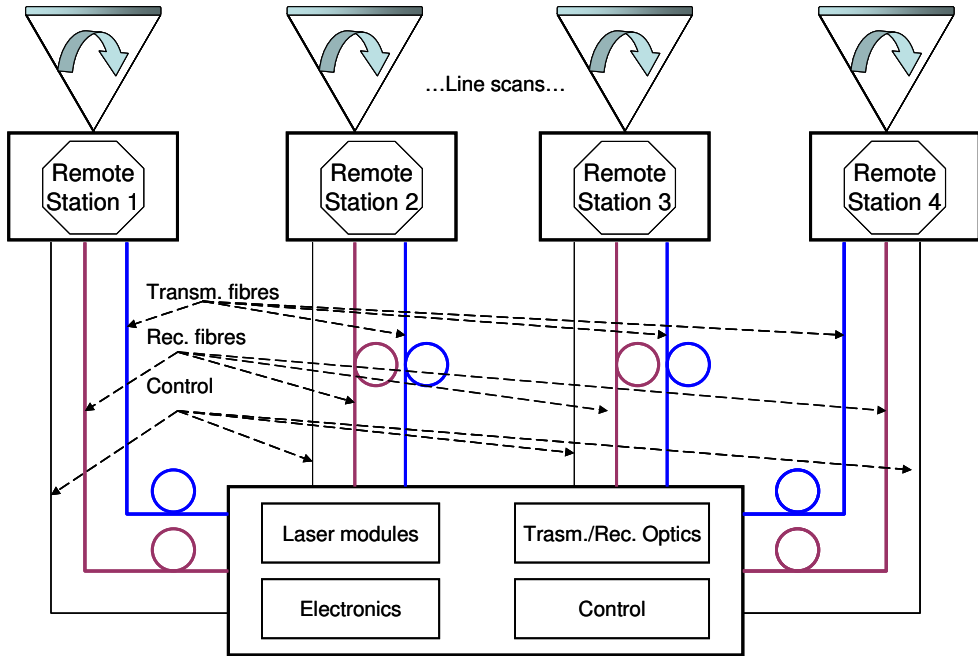

Fig. 7. Overall layout of the telemeter.

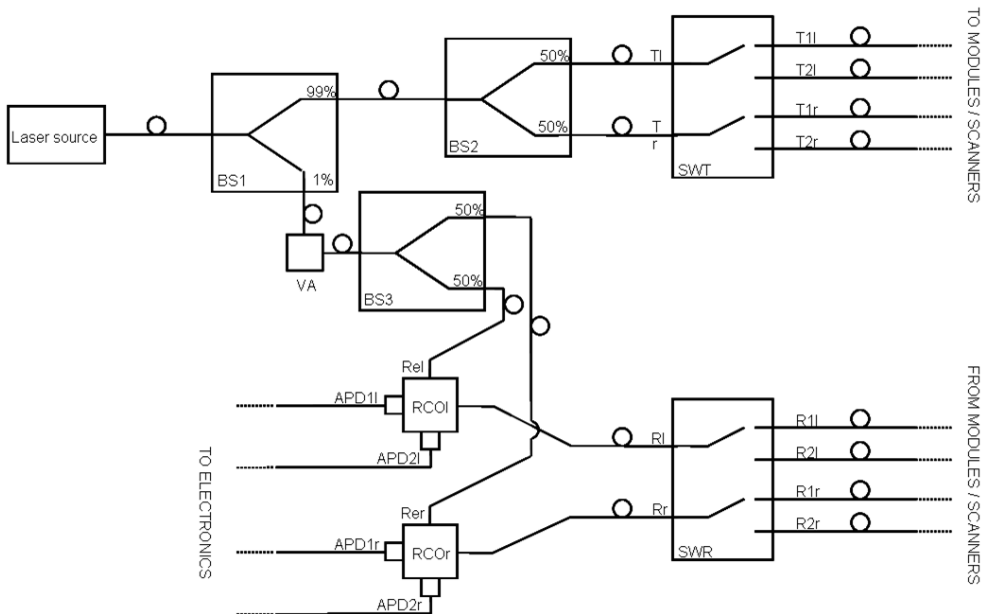

Fig. 8. Optical layout of the central system unit, with transmitter and receiver sections.

3.1.1 Transmitter section

The transmitter section of the system is depicted in the upper part of Fig. 8. The transmitter source is a fast-risetime, short pulse emitter. This can be, according to the application requirements, a high-frequency fibre laser with an output average power of 1.5W, or a nanosecond diode laser. In the application developed for the railway monitoring, the source was a fibre laser emitting pulses having an overall duration of 2.1 ns, and a subnanosecond risetime. The laser fibre has 100 μ m/150 μ m core/cladding dimensions. The repetition rate of the emitted pulses is 400kHz.

The output of either the fibre laser or the diode laser is coupled to a first beam splitter, BS1, that spills 1% out of the transmitter laser power from the main beam, and is sent directly to the receiver unit. Its purpose is to act as the reference, (Re) or "start" signal, as it will be clear later on. The main output of BS1 splitter is then sent to a second, 50%/50% fibre optics splitter BS2, that equally divides the transmitter beam. The two output fibres at the splitter exit deliver the transmitter pulses for the scanning of the left part (Tl) and the right part (Tr) of the train respectively (here the prefix T stands for "transmitter"). The two fibres are directly sent to a 2x4 switch, SWT, that feeds four outputs, two at the same time. These outputs are, respectively, T1l, T1r, and T2l and T2r, and are connected to 100 μ m core fibres that feed the four remote stations.

3.1.2 Receiver section

The 400 μ m receiver fibres from the four scanning stations are here called R1l, R1r, R2l and R2r. They enter the receiver section and are coupled to a second 2x4 switch, SWR. The output of the switch, which is driven by the same control signal that controls the transmitter switch, is composed of two fibres that carry the receiver left signal Rl and right signal Rr respectively. Each fibre is sent to a Receiver collimation optics (RCOl and RCO_r). The 1% part of the Transmitter signal (Re), carried by the fibre at the exit of the first splitter of the transmitter section, enters the receiver section, is attenuated by a variable attenuator and further split in two parts by means of a 50%/50% splitter, BS3. Each of these fibres (Rel and Rer) enters the Receiver Collimation Optics (RCO).

A 40dB dynamic range, difficult to achieve at 400 KHz with standard electronics, has been split in two 20dB dynamic range portions by means of a beam splitter in the RCO. (Fig. 9). Here the Rl (the same holds for Rr) fibre enters the RCO, the beam is collimated and reaches a 10% - 90% beam splitter. The Rel fibre enters the RCO at 90° with respect to the Rl, is also collimated and combined to the Rl signal through the splitter. Two beams are generated: a first one with Rl attenuated 90% and Rel attenuated 10%, and a second beam with Rl attenuated 10% and Rel attenuated 90%.

The purpose of this splitting is clear, since in the presence of very weak optical signals from the object they need to feed a high-gain detector/amplifier system, and in this case most of the signal has to be collected, together with a strongly attenuated reference beam. The opposite holds in the case of strong signals, that feed lower gain detector-amplifier systems.

Each RCO is equipped with two high-speed avalanche photodiodes, APD1 and APD2 [12,13]. The signal from the two photodiodes, as seen in the figure, is composed of a train of two pulses, i.e. the attenuated transmitted pulse, acting as a "start" signal, and the received pulse, acting as a "stop" signal.

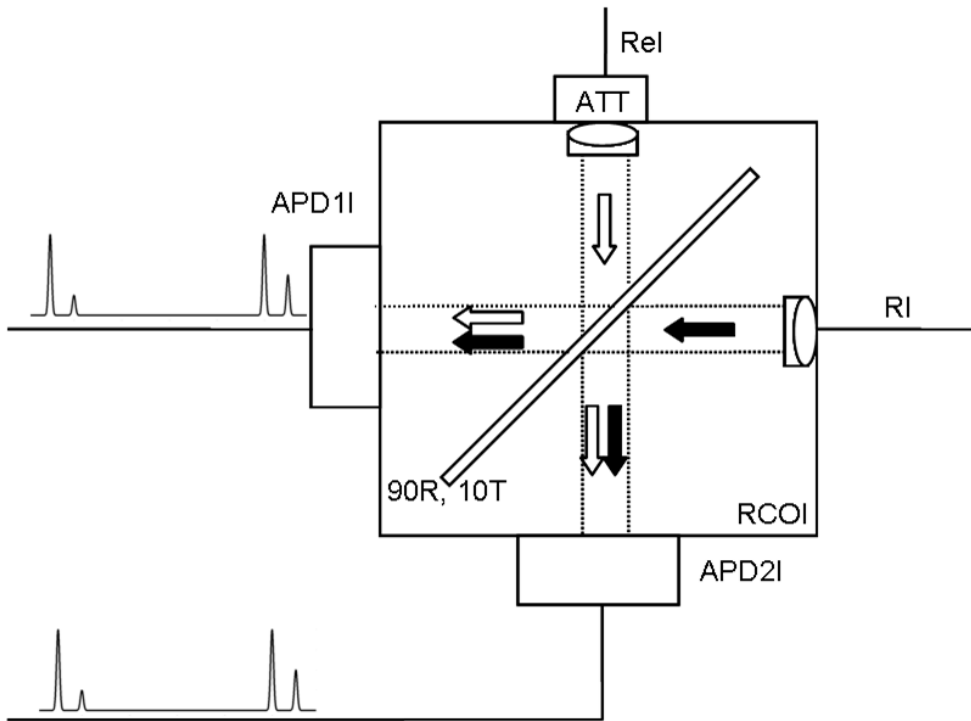

Fig. 9. Detail of the receiver collimation optics (RCO).

3.1.3 Remote stations

Fig. 10 shows the detail of each remote station (as an example, the station “left” of Track 1). The optical fibre T11 enters the module. The beam is collimated and sent to the polygonal scanner rotating at 70 r.p.s. angular speed, driven by the electronic control unit equipped with a position encoder. The polygonal mirror has the purpose of directing the transmitted beam over the required angular range (in our case $\pm 36^\circ$). The beginning and the end of this angle represents the time interval where collected signals are valid.

The Transmitter fibre T11 enters the station and is coupled to the Transmitter/Receiver combination blocks. The fibre output is collimated by the 25mm lens L1, and sent, through a 45° mirror, to the polygonal mirror, and hence to the target. The light diffused by the target reaches, through the polygonal mirror, the combiner: 75% of it passes around the 45° mirror and reaches the 50mm focusing lens L2, that injects it into the receiver fibre R11.

Electrical signals connected to the Remote Stations are the motor start/stop signal, the valid data signal from the encoder, etc.

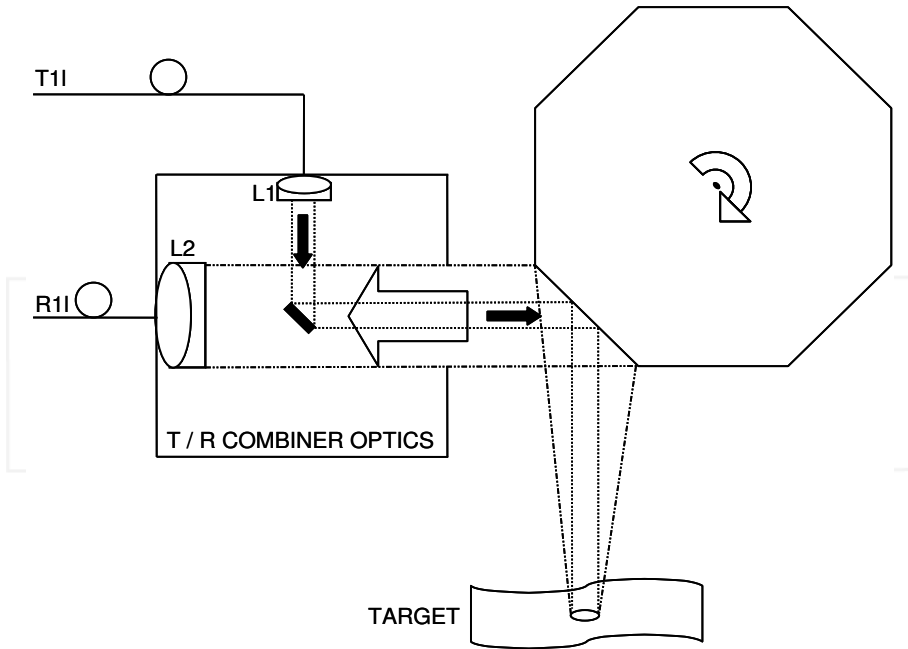

Fig. 10. Optical layout of the remote station, with polygonal mirror and T/R combiner optics.

3.1.4 The system electronics

The output signals from the four APDs described in the Receiver section are sent to the system electronics. They enter the front-end electronics section, with transimpedance amplifiers and conditioning electronics [14-16]. The output of the Front-end Electronics feeds a four-channel Constant Fraction Discriminator (CFD) for the accurate measurement of the arrival time of the train of two pulses for each channel. The digital outputs of the CFD are in turn sent to a Time-to-Distance converter section, which yields the measured distance. Depending on the level of the signal from the receiver, only one of the two signals from the photodiodes should be processed for each couple (l or r). The two signals are sent to two peak detectors, each of them followed by a comparator. If the result of the comparison is positive, i.e., if the APD_l/r can be considered valid, then the result of the time-to-distance conversion is valid. Otherwise, the result of the conversion of the other signal in the couple is valid. All the controls of the electronic unit are made by a control unit based on a FPGA.

3.2 Experimental results

3.2.1 System characterization in house

The laser telemeter has been fully characterized in house to test its performances. A first test consisted in measuring the overall Type B uncertainty with the use of a fixed target of known diffusion coefficient (85% reflectance). The target was accurately placed at a nominal 3m distance from the exit window of the instrument. The nominal distance was in turn

measured by means of a high accuracy laser telemeter. At this distance, the Signal-to-noise Ratio (SNR) of the detected signal was 100.

Fig. 11 shows a typical distribution of the readings obtained from a sequence of 1 Million single-shot samples, carried out at the full frequency of 400 kHz at this position. The analysis of the distribution reveals a standard error of 5mm and an overall accuracy of 2.4mm.

Tests were repeated at various nominal distances, ranging from the minimum distance of 0.5m to the maximum of 20m. The results are summarised in Fig. 12. In the figure the measured distance (left scale) together with the single shot accuracy (right scale) are plotted vs the nominal distance. One notes the excellent linearity of the instrument, with errors well contained in an interval of -5mm - +5mm throughout the nominal distance.

In summary, from the in-house characterization testing it is possible to draw the conclusion that the laser, telemeter, in the version that mounts the fibre laser is well in line with the state-of-art laser telemeters, although operating at much higher frequencies with respect to the existing literature.

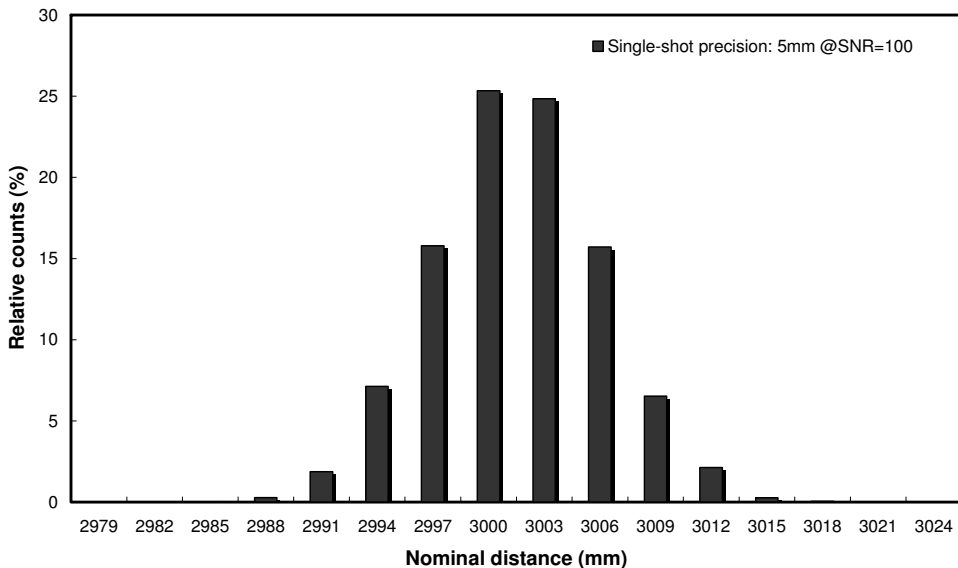

Fig. 11. Distribution of single-shot measurements for a target placed at a nominal distance of 3m from the instrument. SNR: 100. Frequency of acquisition: 400 kHz

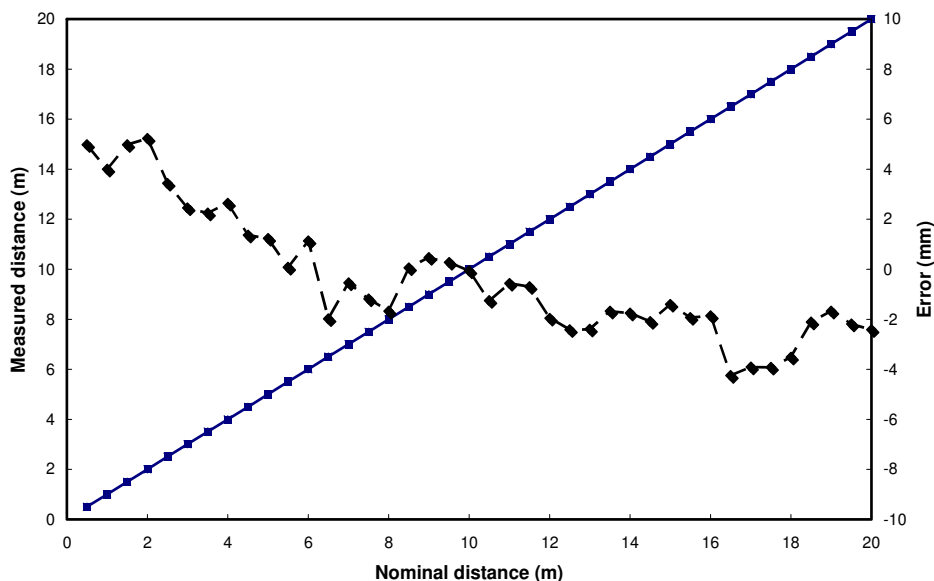

Fig. 12. Plot of the measured single-shot, static distance values (squares, left scale) and of the errors (rhombs, right scale) in a range of nominal distances 0.5 to 20m, at 400 kHz

3.2.2 In-field system testing: The shape monitoring system

The distributed telemeter has been installed on the train-monitoring portal. Here, the four stations have been mounted in such a way as to scan the whole half-carriage under an angle of $\pm 36^\circ$ (positions A, B, C, D of Fig. 1).

The central unit, containing all Transmitter and Receiver Optics and electronics, is placed into a shelter that contains also all the other electronic and computing equipment, well shielded from the vibrations induced by the trains passing through the portal at about 200km/h. The length of the fibres range from 50 to 100m depending on the location of the remote unit to be fed.

The operating laser frequency has been set to 400kHz, thus allowing a complete profile of the left and right side of the carriage to be obtained every 1.4ms.

This results in a longitudinal resolution of 8cm for a train passing under the portal at a speed of 200km/h. A complete convoy having a length of 500m contains about 4 million measure points.

Considering e.g. the locomotive seen in Fig. 5, Fig. 13 shows a typical result of a shape monitoring process. Fig. 13(a) shows the acquisition of the cross-section of the locomotive highlighted by the dotted line in Fig. 13(b). The point cloud of the obtained by combining together all profiles acquired by the Q-Tech time-of-flight telemeter is shown in Fig. 13(c). In this figure, the 3D shape data are combined to the information acquired by the visible cameras.

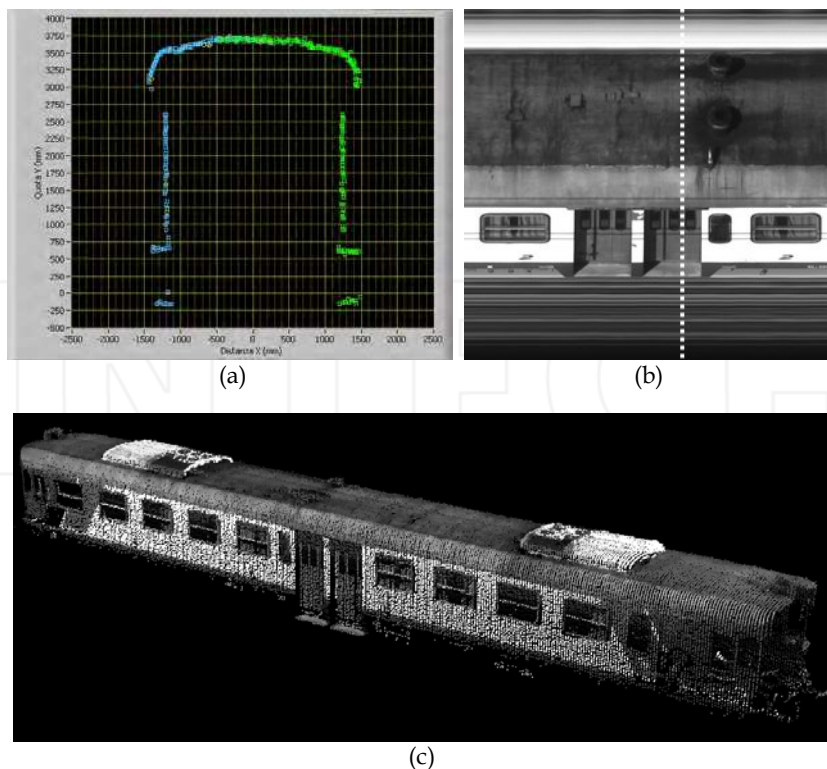

Fig. 13. (a) Acquisition of a single profile of the locomotive shown in Fig. 5; (b) detail of the visual image of the locomotive, highlighting the acquired profile; (c) 3D profile the entire locomotive as obtained by the elaboration of the telemeter measurements.

The point cloud is shown without filtering or digital processing of the points. Nevertheless, in the figure only very few points are evidently “false”, due to particularly unfavourable target conditions (glass, dirt, etc.).

Fig. 14(a) shows a point cloud of a passenger train as obtained by the acquisition and the elaboration of the telemeter measurements; Fig. 14(b) shows the presence of an open door.

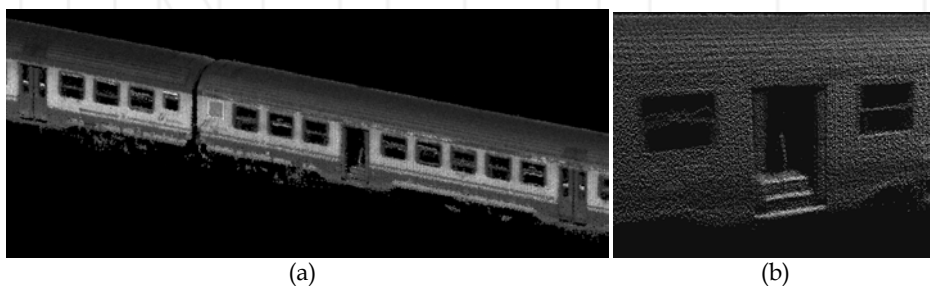

Fig. 14. (a) 3D profile of a passenger train with an open door; (b) detail of the open door.

Fig. 15 shows an example of detection of a shape alarm, i.e. when the measured shape profiles are larger than pre-defined reference shape profiles: Fig. 15(a) shows a profile with an alarm condition; the alarm is caused by a man stretching out his arm, as the visual image acquired by the upper visible camera shows in Fig. 15(b).

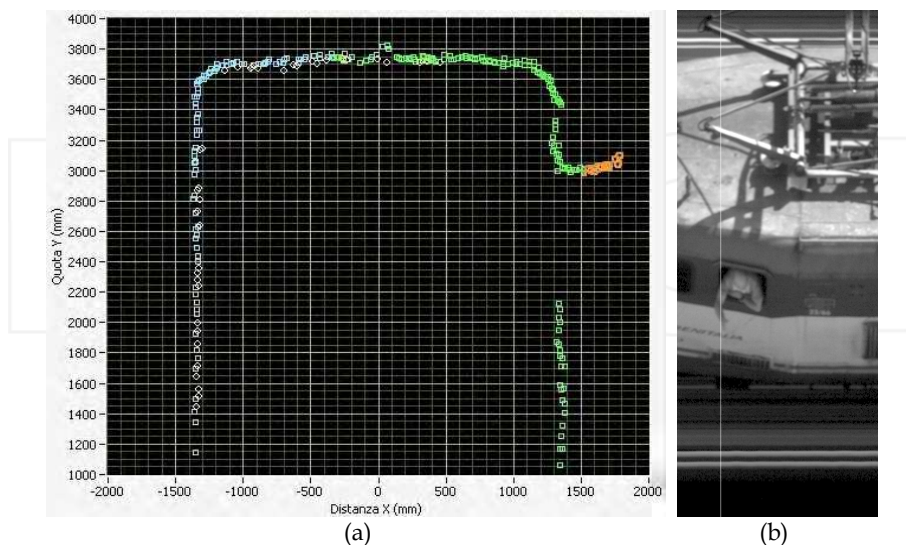

Fig. 15. (a) Profile with a shape alarm; (b) detail of the visual image of the train, highlighting the acquired profile.

The results obtained in the monitoring process are extremely positive for the detection of shape alarms for a train before entering a tunnel.

3.3 Conclusions

The distributed telemeter has proved to be a substantial breakthrough with respect to the previous version based on the phase-shift commercial telemeter. The use of a single transmitter-receiver unit allowed cost reduction of the overall system, increased portability and ease-of-maintenance of the remote stations, protection of the central unit in the shelter. The remote stations resulted to be extremely simplified and lightweight with comparison to the previous version. Considerable increase of the measurement accuracies with respect to the previous version could be obtained without exceeding the emitter power level prescribed by the safety class.

A distributed-architecture concept such as the one described in this paper opens perspectives for the use of the telemeter in a number of multipoint measuring situations without the need of purchasing several telemeters. Robotics, mechatronics and production line monitoring could all be industrial domains where this approach could be beneficial.

For these reasons we plan to implement new versions of the instrument, conceived in a modular way, with all modules connected to standard industrial buses, for laboratory, as well as for industrial applications.

4. References

- [1] H. Höfler, C. Baulig, A. Blug, M. Dambacher, N. Dimopoulos, and H. Wölfelschneider, "Optical high-speed 3D metrology in harsh environments: Recording structural data of railway lines", in: *Optical Measurement Systems for Industrial Inspection IV Proc. SPIE 5856* pp. 296-306, 2005.
- [2] H. Höfler and G. Schmidtke (1994): "Three-dimensional contouring by an optical radar system (ORAS)". In: *Industrial Applications of Laser Radar, Proc. SPIE Vol. 2271*, p. 116-123, 1994.
- [3] A. Blug, C. Baulig, M. Dambacher, H. Wölfelschneider and H. Höfler: Novel laser scanners for 3D mapping of railway tracks or roads. *Conference on Optical 3-D Measurement Techniques 8*, 2007
- [4] H. Höfler, C. Baulig, A. Blug, H. Wölfelschneider, O. Fleischhauer, H. Wirth, J. Meier, C. Lehmkuhler, and H. Lenz, "High speed clearance profiling with integrated sensors". *World Congress on Railway Research (WCRR)*, July 2006, Montreal.
- [5] J. Kalisz, "Review of methods for time interval measurements with picosecond resolution", *Metrologia*, vol. 41, pp. 17-32, 2004.
- [6] T. Bosch, and M. Lecure, *Selected Papers on Laser Distance Measurements*, SPIE Milestone Series, vol. 115, pp. xi – xiii, 1995.
- [7] A. Kilpela, "Pulsed time-of-flight laser range finder techniques for fast, high precision measurement applications", PhD Dissertation, Dept. Electronics, Univ. Oulu university press.
- [8] K. Määttä, J. Kostamovaara, and R. Myllylä, "Profiling of hot surfaces by pulsed time-of-flight laser range finder techniques", *Appl. Opt.* Vol. 32, pp.5334-5347, Sept. 1993.
- [9] I. Kaisto, J. Kostamovaara, M. Manninen, and R. Myllylä, "Optical range finder for 1.5-10 m distances", *Appl. Opt.* Vol. 22, pp. 3528-3264, 1983.
- [10] L. Fumagalli, P. Tomassini, M. Zanatta and F. Docchio: A 400kHz, high-accuracy laser telemeter for distributed measurements of 3D profiles. Submitted to *IEEE Transaction on Instrumentation and Measurements* (2009).
- [11] L. Fumagalli, P. Tomassini, M. Zanatta, and F. Docchio, *Laser Telemeter for Distributed measurements of object profiles*. Italian patent (submitted)
- [12] High-performance emitters & detectors for the most demanding applications, available online at <http://optoelectronics.perkinelmer.com>.
- [13] Avalanche Photodiode - A User's Guide, available online at <http://optoelectronics.perkinelmer.com>.
- [14] P. Battacharya *Semiconductor Optoelectronic Devices*, Prentice-Hall Inc., 1997.
- [15] P. Horowitz, and W. Hill: *The art of electronics*, Cambridge university press, Cambridge, 1989.
- [16] P. Palojärvi, T. Ruotsalainen, and J. Kostamovaara, "A Variable Gain Transimpedance Amplifier with a Timing Discriminator for a Time-of-Flight Laser Radar". *Proc. ESSCIRC'97 Conference*, Southampton, UK, Sept. 16-18 1997, pp. 384-387, 1997.

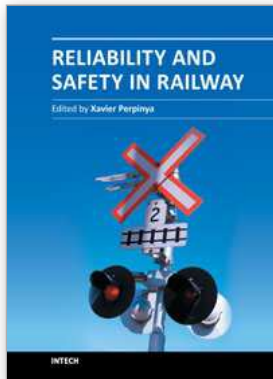

Reliability and Safety in Railway

Edited by Dr. Xavier Perpinya

ISBN 978-953-51-0451-3

Hard cover, 418 pages

Publisher InTech

Published online 30, March, 2012

Published in print edition March, 2012

In railway applications, performance studies are fundamental to increase the lifetime of railway systems. One of their main goals is verifying whether their working conditions are reliable and safety. This task not only takes into account the analysis of the whole traction chain, but also requires ensuring that the railway infrastructure is properly working. Therefore, several tests for detecting any dysfunctions on their proper operation have been developed. This book covers this topic, introducing the reader to railway traction fundamentals, providing some ideas on safety and reliability issues, and experimental approaches to detect any of these dysfunctions. The objective of the book is to serve as a valuable reference for students, educators, scientists, faculty members, researchers, and engineers.

How to reference

In order to correctly reference this scholarly work, feel free to copy and paste the following:

Luca Fumagalli, Paolo Tomassini, Marco Zanatta, Giorgio Libretti, Marco Trebeschi, Giovanna Sansoni and Franco Docchio (2012). Multifunction Portals for Train Monitoring: Recent Advances and Innovative Optoelectronic Instrumentation, Reliability and Safety in Railway, Dr. Xavier Perpinya (Ed.), ISBN: 978-953-51-0451-3, InTech, Available from: <http://www.intechopen.com/books/reliability-and-safety-in-railway/multifunction-portals-for-train-monitoring-recent-advances-and-innovative-optoelectronic-instrumenta>

INTECH

open science | open minds

InTech Europe

University Campus STeP Ri
Slavka Krautzeka 83/A
51000 Rijeka, Croatia
Phone: +385 (51) 770 447
Fax: +385 (51) 686 166
www.intechopen.com

InTech China

Unit 405, Office Block, Hotel Equatorial Shanghai
No.65, Yan An Road (West), Shanghai, 200040, China
中国上海市延安西路65号上海国际贵都大饭店办公楼405单元
Phone: +86-21-62489820
Fax: +86-21-62489821