







Article

Numerical Analysis of a Full-Scale Thermophilic Biological System and Investigation of Nitrate and Ammonia Fates

Maria Cristina Collivignarelli ^{1,2}, Roberta Pedrazzani ³, Stefano Bellazzi ¹, Marco Carnevale Miino ¹,
Francesca Maria Caccamo ¹, Marco Baldi ^{4,*}, Alessandro Abbà ⁵ and Giorgio Bertanza ⁵

- ¹ Department of Civil Engineering and Architecture, University of Pavia, Via Ferrata 3, 27100 Pavia, Italy; mcristina.collivignarelli@unipv.it (M.C.C.); stefano.bellazzi01@universitadipavia.it (S.B.); marco.carnevalemiino01@universitadipavia.it (M.C.M.); francescamaria.caccamo01@universitadipavia.it (F.M.C.)
- ² Interdepartmental Centre for Water Research, University of Pavia, Via Ferrata 3, 27100 Pavia, Italy
- ³ Department of Mechanical and Industrial Engineering, University of Brescia, Via Branze 38, 25123 Brescia, Italy; roberta.pedrazzani@unibs.it
- ⁴ Department of Chemistry, University of Pavia, Viale Taramelli 12, 27100 Pavia, Italy
- ⁵ Department of Civil, Environmental, Architectural Engineering and Mathematics, University of Brescia, Via Branze 43, 25123 Brescia, Italy; alessandro.abba@unibs.it (A.A.); giorgio.bertanza@unibs.it (G.B.)
- * Correspondence: marco.baldi@unipv.it

Abstract: Thermophilic biological processes proved to be effective in aqueous waste (AW) and high-strength wastewater treatment. In this work, the monitoring of a full-scale aerobic thermophilic biological plant treating various high-strength AW in continuous mode is reported. This paper aims to: (i) provide models to help the AW utility manager in predicting the load of fed pollutants and performances, and (ii) fully investigate nitrogen transformations in biological reactor. Based on the results, the thermophilic sludge in the studied plant was able to degrade Chemical Oxygen Demand (COD) and remove nitrate nitrogen with very high efficiency (79.3% and 97.1, respectively). The monitoring was conducted following a statistical approach and searched for the possible correlations between the input parameters and the efficiency of removal of the plant. Moreover, a multivariate linear regression was carried out highlighting that the yield value of the removal of COD and nitrogen forms, apart from ammonia, was well explained ($R^2 = 0.9$) by the linear regression against the other monitored parameters. As far as nitrification is concerned, there was, on the one hand, an increase in ammonium ions due to the hydrolysis of the organic substance that occurs in the reactor, and on the other hand, a stripping of the same ammoniacal nitrogen in the form of NH_3 . While nitrates were effectively removed, according to fluorescent in situ hybridization tests, sludge proved to be formed by minute flocs, where bacteria responsible for the oxidation of ammonium and nitrite seem to be unable to grow.

Keywords: thermophilic biological reactor; aqueous waste; high-strength wastewater; thermophilic biota; respirometric tests; biological sludge; management tool



Citation: Collivignarelli, M.C.; Pedrazzani, R.; Bellazzi, S.; Carnevale Miino, M.; Caccamo, F.M.; Baldi, M.; Abbà, A.; Bertanza, G. Numerical Analysis of a Full-Scale Thermophilic Biological System and Investigation of Nitrate and Ammonia Fates. *Appl. Sci.* **2022**, *12*, 6952. <https://doi.org/10.3390/app12146952>

Academic Editors: Bart Van der Bruggen and Chang-Gu Lee

Received: 24 May 2022

Accepted: 5 July 2022

Published: 8 July 2022

Publisher's Note: MDPI stays neutral with regard to jurisdictional claims in published maps and institutional affiliations.



Copyright: © 2022 by the authors. Licensee MDPI, Basel, Switzerland. This article is an open access article distributed under the terms and conditions of the Creative Commons Attribution (CC BY) license (<https://creativecommons.org/licenses/by/4.0/>).

1. Introduction

The disposal of aqueous waste (AW) represents a critical problem due to the high variability of their physico-chemical characteristics [1]. Biological processes in conventional wastewater treatment plants (WWTPs) are not able to remove certain types of pollutants and in some cases, the plant's biota could also be inhibited [2,3]. Therefore, proper pre-treatments are needed.

To date, several additional treatments are available for increasing the acceptance of conventional biological processes, reducing acute or chronic toxicity effects due to the presence of high refractory organic compounds [4,5].

Despite their large use, physico-chemical treatments present several drawbacks, such as high operating costs related to chemical agents and the need for highly specialized

personnel in their management [6]. On the contrary, biological processes have greater management simplicity, lower costs, and a lower probability of the formation of dangerous treatment by-products [7].

Among the biological treatments, the scientific community agrees that thermophilic treatments can perform high yields of removal additionally in the case of recalcitrant pollutants [8,9]. While mesophilic bacteria are widely used in the treatment of urban wastewater and work in a temperature range of 15–30 °C, thermophilic biota are widely used for the treatment of AW and find optimal conditions at temperatures between 50–60 °C [10]. For instance, in previous works, a thermophilic biological process was combined with an ultrafiltration membrane system to overcome sludge settleability issues and maximize performance, guaranteeing purification yields of the organic load of 95% [11]. This technology also granted the ability to treat different types of pollutants in high-strength AW in terms of COD content and surfactants [12] being applied in two full-scale plants [13,14].

This process was recently tested for biological sludge minimization, providing excellent results in terms of Total Solids (TS) and Volatile Solids (VS) reduction, and granting minimization of biological sludge production in WWTPs up to 90% [15]. This reduction was assured by the degradative and reproductive kinetics of a thermophilic biomass. In fact, thermophilic bacteria have a lower tendency to reproduce than traditional mesophilic bacteria [16].

So far, the statistical-based characterization of AWTP has received relatively poor attention in the literature. Harrou et al. [17] applied a statistical approach to derive alerts conditions in the management of the plant. The same strategy has been presented in Aguado and Rosen [18], but the analysis has been carried on simulated data. Muszyński et al. [19] reported a statistical study to correlate the amount of VS and the environmental data (COD and BOD₅). O'Brien and Teather [20] developed a predictive model successfully applied to estimate the pollutant concentrations in a biological system (activated sludge). Therefore, our approach represents a clear novelty, since it increases the number of environmental variables if compared to previous studies of a plant of novel conception, based on a thermophilic biological reactor.

In this work, the monitoring of a full-scale aerobic thermophilic biological plant treating various high-strength aqueous waste (AW) in continuous mode is presented. The main novelty points of this work are:

- The application of multivariate statistical analysis to evaluate possible correlation between several pollutants fed and performances of the process to give a useful tool to aqueous waste treatment plant (AWTP) utility manager;
- The adoption of respirometric tests to confirm results obtained by monitoring data analysis and to fully understand ammonia fate in the reactor;
- A microbiological characterization of thermophilic biota presents in a full-scale thermophilic membrane biological reactor, focusing on nitrogen oxidation.

2. Materials and Methods

2.1. Characteristics of the Aqueous Waste Treatment Plant (AWTP)

Monitored AWTP was generally fed with a wide range of high-strength AW: saline, neutral, acid, or wastewater basic high strength wastewater, landfill leachate, solvents wastewater, and wastewater rich of pharmaceutical compounds. The water line is composed by both chemical-physical and biological treatments (Figure 1). This work focuses only on thermophilic system composed by a thermophilic biological reactor (TBR) followed by ultrafiltration (UF) membranes.

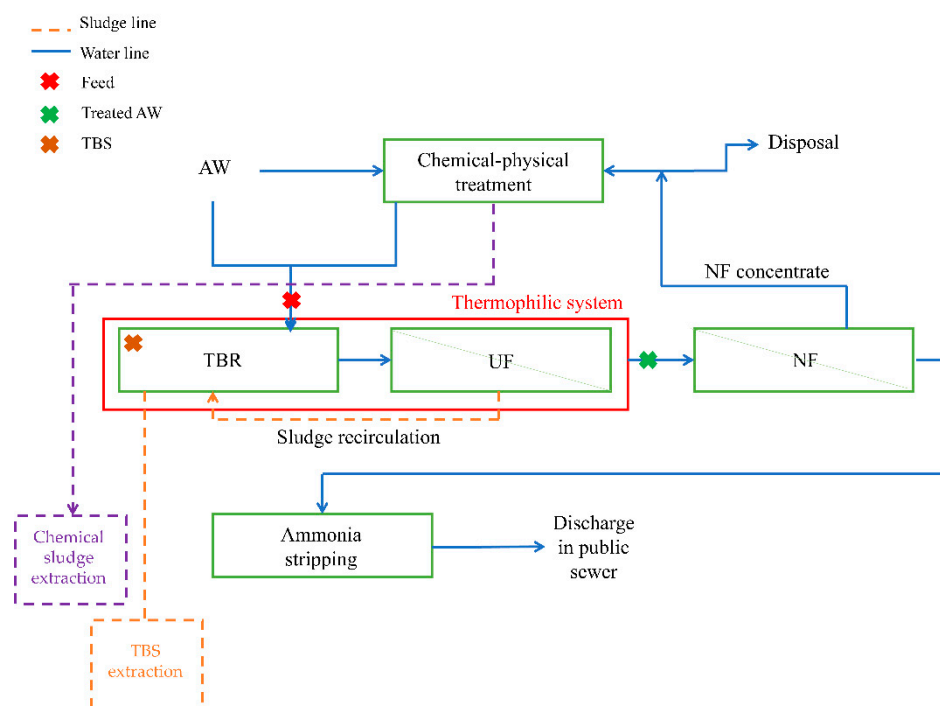

Figure 1. Scheme of the AWTP and sampling points (X). AW: Aqueous waste; NF: Nanofiltration; TBR: Thermophilic biological reactor; TBS: Thermophilic biological sludge; UF: Ultrafiltration.

As can be seen from the process scheme, aqueous waste has two treatment options based on its characteristics. The “light” waste is fed directly to the TBR, while the more resistant waste is pre-treated in two chemical-physical compartments in order to prevent a possible inhibition effect on thermophilic biomass ($T = 48\text{ }^{\circ}\text{C}$). The TBR has a volume of 1000 m^3 and is characterized by an average inlet flow rate $Q_{in} = 170\text{ m}^3\text{d}^{-1}$, with a hydraulic retention time HRT of almost 6.0d. To obtain a more compact sludge structure, a dissolved oxygen concentration of $1.5\text{--}2\text{ mg L}^{-1}$ in the reactor is guaranteed by the injection of pure oxygen. The biological tank have a diverse oxygen concentration. This management strategy allows both the aerobic removal of the organic substance in zones with oxygen concentration ($2\text{ mgO}_2\text{ L}^{-1}$), and the denitrification in anoxic zones ($<1\text{ mgO}_2\text{ L}^{-1}$) [13,14]. As previously mentioned, the TBR is coupled with an ultrafiltration system due to the poor sedimentation of the thermophilic sludge. Therefore, the platform is equipped with two parallel UF units and a nanofiltration unit (NF). The UF unit consists of three vessels with 99 ceramic membranes (300 kDa cut-off) with an operating pressure between 3 and 5 bar. As shown in Figure 1, the retentate UF is recirculated in the biological tank. NF and ammonia stripping compensate the further treatments.

2.2. Monitoring Plan

Monitoring activity was focused on the thermophilic system (TBR + UF) from 2017 to 2021, sampling feed and permeate of ultrafiltration (Figure 1) three times a week for five years. Analyses of COD, nitrogen species (N_{tot} , $N\text{-NO}_x$, $N\text{-NH}_4^+$), total phosphorus (P_{tot}), total solids (TS), and volatile solids (VS) were performed according to standard methods [21]. The flow rates into and out of the plant, as well as the consumption of pure oxygen required for the organic substance degradation (C_{O_2}), were all monitored daily. Finally, the extraction of sludge from the TBR was monitored, as this operation was necessary to avoid overloading of the thermophilic process. Based on the monitored value, the sludge load (C_f) and the sludge age (θ) were calculated according to Masotti [22].

Respirometric tests (ammonia uptake rate–AUR; nitrogen uptake rate–NUR) were carried out twice a week for a total period of 4 months. Over a period of two months, samples of activated sludge were collected weekly to be submitted for microbiological

analysis by means of the fluorescent in situ hybridization technique (FISH), in order to investigate the bacterial populations colonizing the plant. Special attention was paid to the oxidation of ammonia nitrogen. The FISH technique was chosen due to its peculiar ability to ensure visualisation of the floc without altering its morphology. This ensured it was possible to highlight viable bacterial populations and, in turn, target micro-organisms (in this case, AOB, NOB and ANAMMOX).

2.3. Data Processing

To determine the removal efficiency of COD, nitrogen, and total phosphorus, mass balances were performed weekly based on fed and extracted loads.

All parameters were studied by a multiple linear regression analysis. Firstly, to obtain correct modeling, the data were normalized for the maximum value of the series to obtain a series of homogeneous values between 0 and 1. Correlations between measured parameters and performances have been computed with both Pearson's and Spearman's rank correlation [23].

The overall behavior of the thermophilic system has been described with a set of multivariate linear regressions, where each physicochemical parameter of the plant has been modeled as a linear combination of the others. A stepwise regression method has been applied by Matlab function *stepwisefit* [24] to select the variables that are more strongly jointly correlated with each of the plant parameters. Given the i -th parameter x_i , it is described with the model:

$$x_i = \alpha_i + \sum_{j \neq i} \beta_{ij} x_j \quad (1)$$

If m parameters are measured, the stepwise procedure allows selecting the $m_i \leq m - 1$ parameters that are more statistically significant to predict each x_i .

2.4. Respirometric Tests

To evaluate the activity of nitrifying and denitrifying biota AUR and NUR tests were performed. Tests were carried out according to Collivignarelli et al. [13].

In the case of NUR tests, the AW feed to the thermophilic system was used as an organic substrate. The thermophilic biomass sampled in the TBR was used to carry out the NUR and AUR tests. Two diverse biomass/substrate (B/S) ratios were tested: 1/1 and 1/7 to investigate the kinetics of NUR both under the standard test conditions (B/S ratio = 1/1) and by reproducing the real plant conditions (B/S ratio = 1/7).

2.5. Fluorescent In Situ Hybridization

After collection, samples were added with absolute ethanol (1:1) and stored at $-20\text{ }^{\circ}\text{C}$ until measurement. DNA probes (vermicon AG, Munchen, Germany) for the detection of viable bacteria, ammonia oxidizers (Nitri-VIT[®]), nitrite oxidizers (Nitri-VIT[®]), and ANAMMOX (VIT[®] Anammox) were applied. After hybridization, slides were observed under fluorescence microscopy (Axioscope, Zeiss, Milano, Italy) by using the FS09-Blau Anreg. FITC LP 1046-281 filter set (excitation BP 450-490 nm; beamsplitter FT 510; emission: LP 515 nm) and the F11-002 Grün Anreg. TRITC LP 1046-281 filterset (excitation BP 546/12 nm; beamsplitter FT 580; emission: LP 590 nm respectively).

3. Results and Discussion

3.1. Monitoring of the Biological Thermophilic System

As can be seen in Table 1, the loads of fed pollutants and performances of biological thermophilic process were reported. Biomass was able to treat high COD loads, with a concentration of two orders of magnitude higher, up to $50,000\text{ mg L}^{-1}$, than conventional activated sludge (CAS) systems where the concentration of COD in input is almost $200\text{--}400\text{ mg L}^{-1}$ [17–20], with almost constant performance throughout 5 years of monitoring around 80%. As regards to nitrite and nitrate, removal of yields higher than 95% were granted for the entire monitoring period. Focusing on ammonia removal, a negative value

was recorded. This result is confirmed in our previous study [11] where the enhancement of ammonia concentration during the thermophilic biological treatment was related to a strong ammonification phenomenon. If compared with the performance values of a CAS plant, the ability of the TAMR plant to obtain very high removal yields of nitrates is highly relevant [25]. The removal and production yields relating to nitrates and ammonia, respectively, are then reflected in the abatement yields of total nitrogen. In the five years of monitoring, the performances on total nitrogen were the most variable, going from a minimum value of 62% for 2019 to a maximum value of 76.7% recorded in 2021. Comparing the feed and the permeate, significant removal of phosphorus is pointed out at 82%. This result agrees with our previous study [13], in which the accumulation of phosphorus in the sludge in inorganic form was pointed out. The capacity of the TAMR plant, therefore, allows it to accumulate phosphorus inside the sludge making it rich in nutrients and, therefore, susceptible for possible recovery in agriculture.

Table 1. Loads of pollutants fed and performance of the thermophilic system. n: number of data.

Parameters	2017 (n = 51)	2018 (n = 52)	2019 (n = 52)	2020 (n = 38)	2021 (n = 51)	2017–2021 (n = 244)
COD IN (kg w ⁻¹)	30,560 ± 1543	33,683 ± 1580	34,366 ± 1925	30,423 ± 1883	29,297 ± 1225	31,665 ± 1631
μ COD (%)	77.6 ± 2.2	80.9 ± 1.5	77.7 ± 1.9	80.3 ± 2.0	80.1 ± 2.6	79.3
N-NO _x IN (kg w ⁻¹)	1503 ± 151.8	1808.7 ± 157.7	1937 ± 164.5	1722 ± 207.8	1982 ± 185	1791 ± 173
μ N-NO _x (%)	95.4 ± 1.8	97.5 ± 0.7	97.7 ± 0.6	99.2 ± 0.2	95.7 ± 3.6	97.1
N-NH ₄ ⁺ IN (kg w ⁻¹)	280.7 ± 26.63	382.5 ± 46.3	468.6 ± 42.66	462.1 ± 57.0	237.2 ± 39.6	366 ± 42.4
μ N-NH ₄ ⁺	-64.9 ± 29.5	-63.8 ± 48.8	-103.7 ± 38.9	-40.1 ± 17.1	-21.3 ± 20.9	-58.6
N _{tot} IN (kg w ⁻¹)	3243.5 ± 241.7	4020.4 ± 463.3	3569 ± 417.8	3039 ± 241.7	2983 ± 420	3371 ± 357
μ N _{tot} (%)	70.2 ± 2.3	69.6 ± 3.6	62.0 ± 3.3	67.1 ± 4.5	76.7 ± 3.6	69.1
P _{tot} IN (kg w ⁻¹)	336.1 ± 58.5	245.8 ± 48.2	326.3 ± 43.0	279.3 ± 47.4	299.3 ± 37.6	297 ± 47
μ P _{tot} (%)	81.0 ± 6.46	80.1 ± 5.1	84.6 ± 1.9	85.3 ± 6.2	80.1 ± 2.6	82.2
C _{O2} (kgO ₂ CODrem ⁻¹)	1.47 ± 0.1	1.26 ± 0.1	1.28 ± 0.1	1.66 ± 0.3	1.44 ± 0.1	1.42 ± 0.1
TS (kg m ⁻³)	205.2 ± 4.6	220.6 ± 5.5	208.2 ± 6.2	180.1 ± 6.4	186.1 ± 7.2	200 ± 6.0
VS (kg m ⁻³)	52 ± 2.7	50.2 ± 2.6	47.7 ± 5.4	47.1 ± 3.6	48.2 ± 3.2	49 ± 3.5
C _f (kg _{BOD} (kg _{SST} d) ⁻¹)	0.02 ± 0.01	0.02 ± 0.01	0.02 ± 0.01	0.02 ± 0.01	0.02 ± 0.01	0.02 ± 0.01
θ (d)	252 ± 19	206.9 ± 19.7	184.6 ± 15.9	232.0 ± 2.6	233.1 ± 2.3	221.7 ± 11.9

The specific oxygen consumption, C_{O2} was influenced by the biodegradability of the organic matter fed. It remains constant for all years monitored and is equal to 1.42 kgO₂ CODrem⁻¹, this value represents a significant index of the operating conditions of the plant, in fact it allows to quantify the oxidizing agent necessary to degrade 1 kg of organic substance. TS in the TBR was 180.1–205.0 g L⁻¹ and the value of VS remained constant over the years of monitoring at around 47.1–52.0 g L⁻¹. These very high solids concentrations allow us to consider this operating reactor as a fluidized bed process [26]. Sludge load (C_f) and sludge age (θ) provided an indication of the operating conditions of the thermophilic biological process. The sludge load remained almost constant for all monitoring years (0.02 kg_{BOD} (kg_{SST} d)⁻¹). θ indicates the number of days in which biomass remained in the biological system. The average value (221.7 ± 11.9 d) was one order of magnitude higher than a traditional CAS plant (5–20d) [22]. This aspect was due to a lower production of VS typical of thermophilic system [9], which helped to produce a lower amount of excess sludge and more stabilized [27]. This aspect was extremely important for AW utility managers from an economic point of view since sludge production from biological systems represented one of the major cost items in plant management [28]. Over monitored years, θ strongly decreased in 2018 and 2019 to 206.9 ± 19.7 d and 184.6 ± 15.9 d,

respectively, increasing again in 2020 and 2021 up to 233.1 d. This result was due to a higher sludge extraction in 2018 and 2019 ($8.4 \pm 1.6 \text{ t}_{\text{TS}} \text{ w}^{-1}$ and $9.1 \pm 1.5 \text{ t}_{\text{TS}} \text{ w}^{-1}$, respectively) with respect to other monitored years (2017: $6.4 \pm 0.8 \text{ t}_{\text{TS}} \text{ w}^{-1}$; 2020: $5.8 \pm 0.2 \text{ t}_{\text{TS}} \text{ w}^{-1}$; 2021: $5.4 \pm 0.2 \text{ t}_{\text{TS}} \text{ w}^{-1}$).

3.2. Data Analysis

3.2.1. Pearson and Spearman Correlation Coefficients

Pearson moment correlation coefficient and Spearman rank correlation coefficient were calculated to evaluate a possible correlation between the monitored parameters and calculated performances of the thermophilic biological process. Spearman’s correlation index S is a non-parametric statistical measure of correlation, it measures the degree of relationship between two variables. The Pearson correlation index P between two statistical variables is an index that expresses a possible linearity relationship between them.

From the analysis of Pearson’s correlation index (Figure 2), a positive correlation between the COD fed at the system and nitrates were pointed out (0.44), This consideration explains the value of 0.36 between the yield of removal nitrates and the yield of removal COD. The COD entering the plant is positively correlated to the amount of oxygen consumed (0.42) and the total nitrogen treated (0.36). CODin and COD are related to oxygen consumption; as the organic substance increases, the amount of oxygen needed to degrade it also increases. It is also possible to note some negative correlations, such as the ammonia entering the plant seeming to negatively influence the total nitrogen and COD abatement yields, suggesting a treatment upstream of the biological process. High concentrations of ammonia entering the TBR can lead to a reduction in total nitrogen removal yields and COD [29].

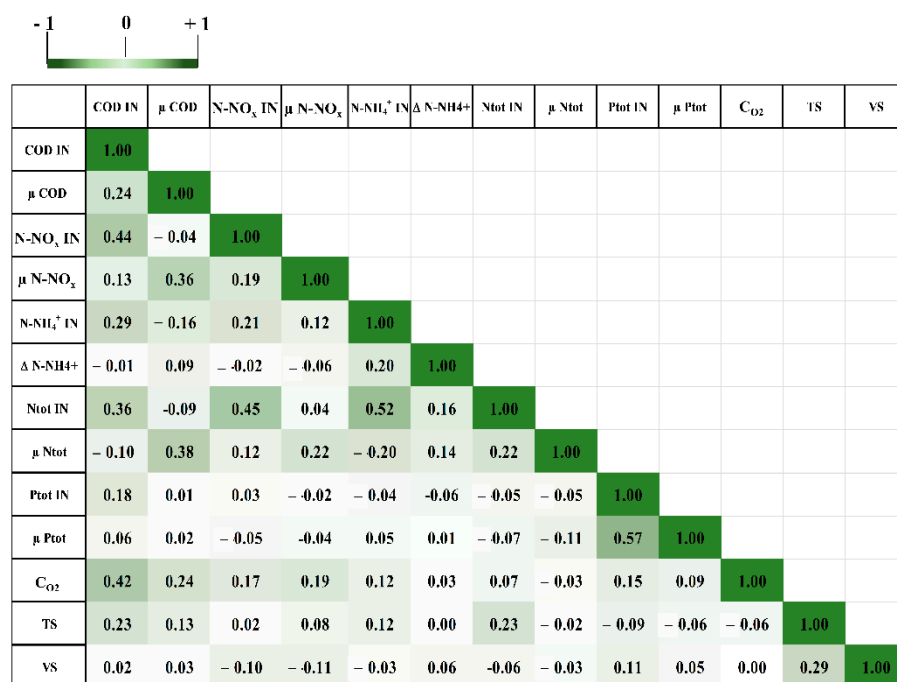

Figure 2. Pearson’s correlation matrix.

Spearman’s correlation matrix shows very similar results (Figure 3). Further, in this case, there is a negative correlation between ammonia entering the plant and the reduction yields of removal COD and total nitrogen. We can see that the correlation coefficient passes from the value of -0.16 in the matrix P to a value -0.29 in the matrix S. These results confirm the negative correlation between these two parameters, ammonia, and fed COD. It is possible to see a solid positive correlation between the nitrates fed to the system and the total nitrogen fed. This correlation can be explained considering that nitrates are the

most considerable portion of the nitrogen forms treated by the thermophilic biological system. Also, a negative correlation index of total phosphorus removal vs. TS (−0.03) was pointed out.



Figure 3. Spearman’s correlation matrix.

From the analysis of the two correlation matrices, a positive correlation emerges between all the polluting parameters monitored at the entrance to the TBR. This management choice is positively reflected in the performance analysis, shown in Table 1, which shows very high-performance values for all the polluting parameters analyzed except for ammonia nitrogen.

If Pearson (P) < Spearman (S), this means a monotone correlation, but not a linear one [30]. Results could help in the future in the correct modeling of the observed parameters, giving information on the type of correlation between the data, whether linear or monotone. The negative correlation index between the total phosphorus abatement yields and the total solids concentration increase in the Spearman’s matrix means the correlation between the two data is monotone but not linear.

The results obtained can be compared with the results presented by Muszyński et al. [19], in which the bacterial species are correlated with the COD and BOD₅ removal yields in our work instead the Spearman and Pearson matrices are made between the diverse environmental parameters of the plant.

3.2.2. Multivariate Linear Regression

Tables 2 and 3 show the matrices of coefficients of a set of multiple linear regressions, where each parameter is seen as a function of the other parameters monitored by the plant. It was decided to differentiate the parameters between two diverse groups: (i) fed loads of each polluting chemical parameter, and (ii) the yields of removal together with process parameters.

Table 2. Coefficients of multivariate linear regressions of input loads. Rows are indicative of the modeled parameters, while the columns represent coefficients of the model. α_i , intercept value with ordinate axis.

	COD IN	N-NO _x IN	N-NH ₄ +IN	Ntot IN	Ptot IN	α_i
COD IN	-	0.2927	0.1762	-	0.1119	0.4
N-NO _x IN	0.4199	-	-	0.5212	-	0
N-NH ₄ +IN	0.1532	-	-	0.7021	-	0
Ntot IN	-	0.2262	0.3015	-	-	0.02
Ptot IN	0.3595	-	-	-0.2545	-	0.4

Table 3. Coefficients of multivariate linear regressions of yields and physical process parameters. Rows are indicative of the modeled parameters, while the columns represent coefficients of the model. α_i , intercept value with ordinate axis.

	μ COD	μ N-NO _x	Δ N-NH ₄ ⁺	μ Ntot	μ Ptot	C _{O2}	TS	VS	α_i
μ COD	-	0.2722	-	0.1858	-	0.1563	0.1047	-	0.31
μ N-NO _x	0.3223	-	-	-	-	-	-	-0.0994	0.73
Δ N-NH ₄ ⁺	-	-	-	1.3883	-	-	-	-	0
μ Ntot	0.735	-	-	-	-	-0.1661	-	-	0.16
μ Ptot	-	-	-	-	-	-	-	-	0.55
C _{O2}	0.3959	-	-	-0.1039	-	-	-	-	0.09
TS	0.147	-	-	-	-	-	-	0.3268	0.43
VS	-	0.0493	-	-	-	-	0.2711	-	0.13

From Table 2 it is possible to highlight that Ptot and N-NH₄⁺ removal yields were never used as a parameter useful for modeling, and Ptot was not the result of the linear regression of any other parameter.

Figure 4 shows the comparisons between the values measured in the plant and the values estimated by the multiple linear regressions. Thanks to these comparisons, it is possible to appreciate the excellent goodness-of-fit of the regression models. In particular, the yield value of removal COD and nitrogen forms, apart from ammonia, is well explained by the linear regression against the other monitored parameters. In regard to the COD entering the plant and the COD efficiency, the relationships between measured and estimated values have an angular coefficient of 1.059 and 1.003 with an R² of 0.98 and 0.99, respectively.

Similar results were obtained by observing the graphs of the input and the reduction of nitrates. In this case the slope of the interpolating line was 0.923 and 0.982 associated with R² values of 0.928 and 0.996, respectively. Also, in this case, it is possible to state that the multiple linear regression model allows estimating the data with an excellent degree of precision. In the case of N-NO_x, however, the model tends to slightly underestimate the predicted value compared to the observed one.

This type of analysis allows the AW utility manager to predict the number of certain pollutants or performances of the thermophilic biological system in presence of a limited amount of data.

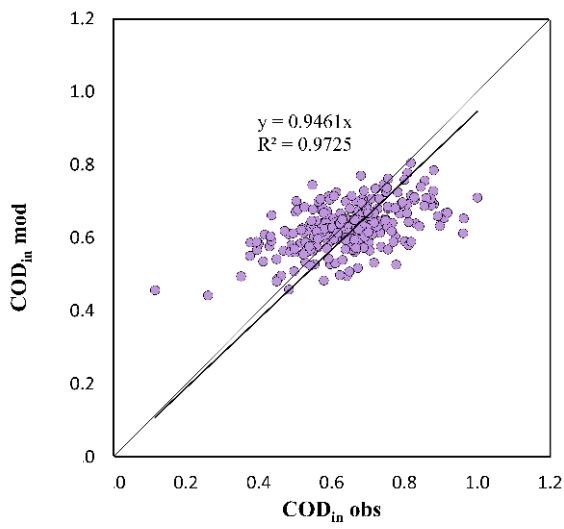

(a)

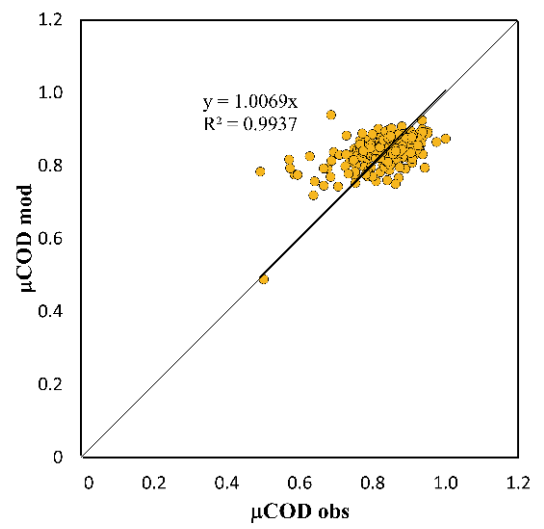

(b)

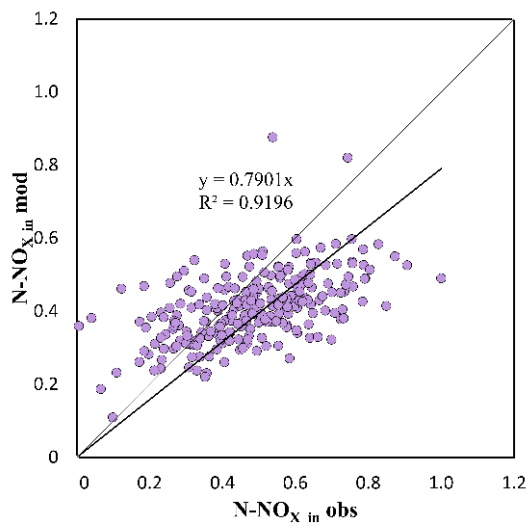

(c)

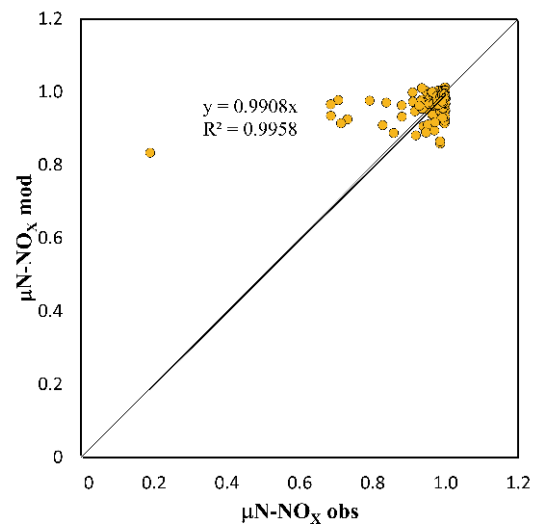

(d)

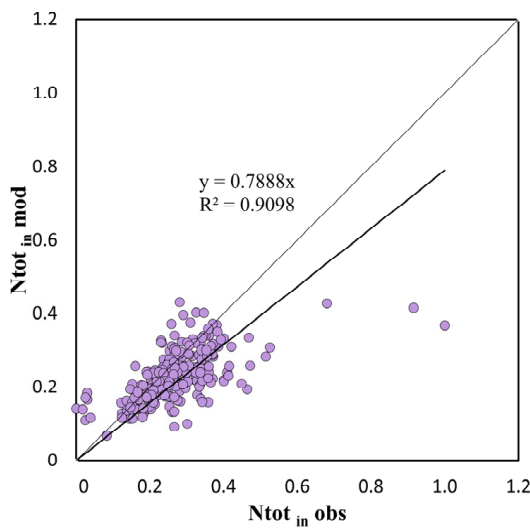

(e)

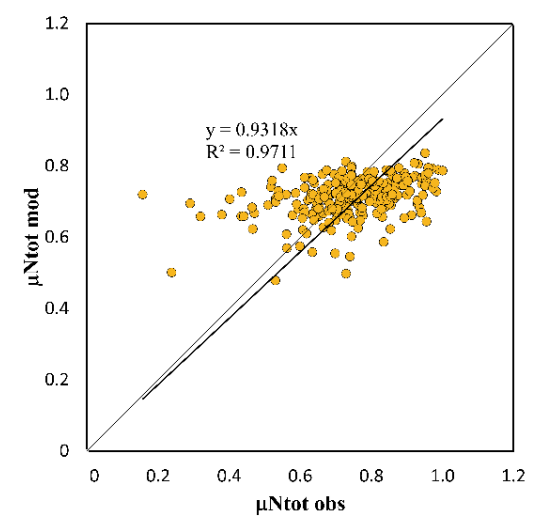

(f)

Figure 4. Cont.

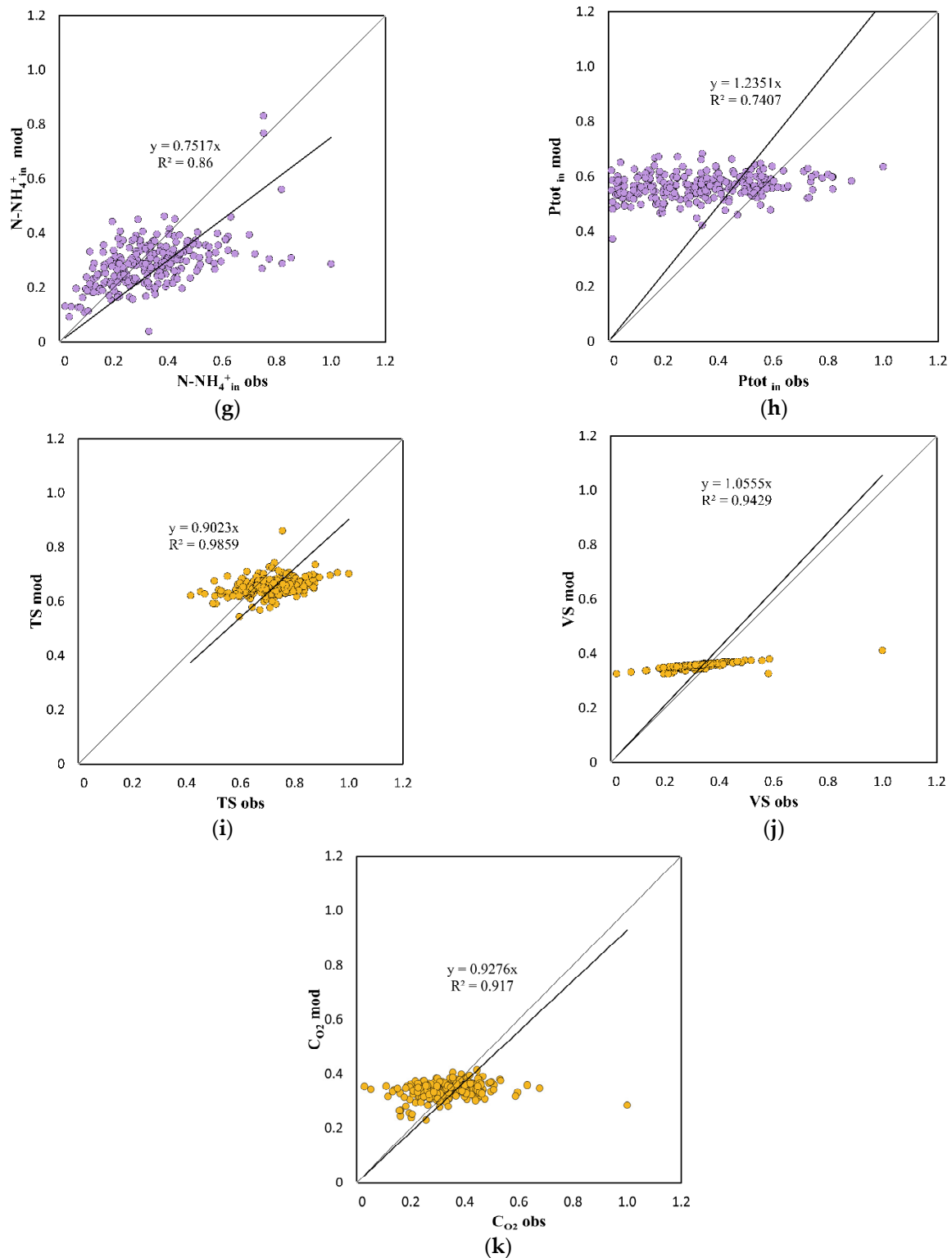

Figure 4. Multivariate linear regressions: comparison between normalized observed value and modeled values. Figures from (a–k) show the trend of the measured values and of the modeled values considering both the concentrations of pollutants in input and their removal efficiency.

3.3. Respirometric Tests

Ammonia Uptake rate tests (AUR) tests were carried out to evaluate the nitrifying activity of the thermophilic biomass. In respirometry tests, no nitrification activity was

detected. This study showed that uncommon ammonia removal was caused by stripping due to pure oxygen injection rather than microbiological transformation. The microbiological analyses highlighted the absence of nitrifying biomass (see Section 3.3). Indeed, these results completely agree with previous literature findings. At thermophilic temperatures, above 45 °C, nitrification processes do not take place and the bacteria due to this process are totally inhibited [31].

The nitrogen uptake rate (NUR) findings confirm the ability of the thermophilic biomass in denitrifying nitrogen in thermophilic conditions (Figure 5). Data from the monitoring of the system suggested nitrates removal higher than 95%.

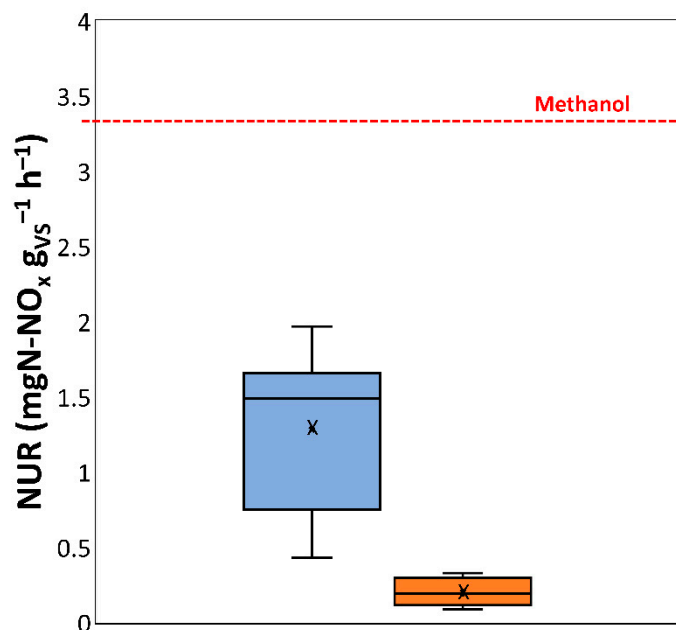

Figure 5. Results of NUR tests and comparison with the literature value [13,32] obtained with methanol dosage as a carbon source.

The potential of thermophilic bacteria to decrease nitrates over time was confirmed by the findings. Tests carried out under standard conditions have very high NUR kinetics (1–1.7 mgN-NO_x gVS⁻¹ h⁻¹). The tests carried out to keep the test reports equal to the real plant ratio showed definitely lower values, equal to 0.21 mgN-NO_x gVS⁻¹ h⁻¹. The two values are lower than the value found in the literature, relating to mesophilic biomass with carbonaceous source methanol, an excellent substrate according to the literature [28].

To obtain feedback on the very high nitrate abatement performance, it is necessary to pay attention to the concentration of solids in the tank. In fact, as can be seen in Figure 5, the denitrification kinetics of the thermophilic biomass taken under the real plant conditions is equal to 0.21 mgN-NO_x gSV⁻¹ h⁻¹. The very high removal yields are, therefore, guaranteed by the high concentration of VS in the TBR (50 kg m⁻³). Considering the obtained kinetics and the content of VS, the biological system was able to remove almost 1680 kg of nitrates in the HRT of the system, which was 94% of the fed N-NO_x at the same time 1791 kg. This aspect confirms the results obtained by monitoring of the full-scale system.

3.4. Biota Characteristics

In any case, no AOB (Ammonia Oxidizing Bacteria), NOB (Nitrite Oxidizing Bacteria), and anammox bacteria were identified. If we compare the results with the results of the analysis carried out on samples from the same AWTP plant, which was the subject of a publication by Abbà et al. [33], despite the large time interval between the two measurements, we note the continued absence of nitrifying bacteria. Figure 6 displays a picture of

the flocs, which have a diameter always lower than 150 μm and are quite dense, without any bone of filaments, as previously highlighted. Red spots represent the viable bacteria.

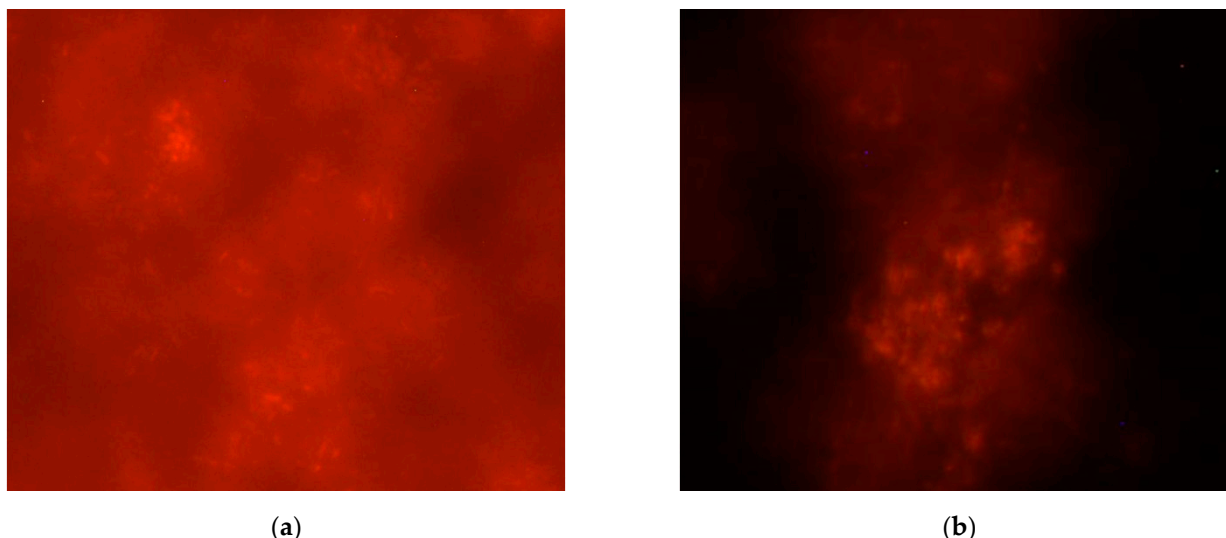

Figure 6. Micrographs of the sludge after fluorescent in situ hybridization, under red fluorescence. Red spots represent viable bacteria clusters (magnification: 1000 \times). Photos (a,b) representing the same sample at two different times.

The biomass of this plant proves to be quite peculiar, given the particular process conditions that lead to the development of minute flocs and a bacterial community whose populations are present in different percentages compared to conventional activated sludge. The bacteria responsible for the oxidation of ammonium and nitrite seem to be unable to grow.

4. Conclusions

In this work, a full-scale aerobic thermophilic biological plant treating various high-strength AW was monitored for five years. The process scheme and operating conditions, in terms of input load, temperature, dissolved oxygen concentration, and salt content make the biomass of the plant studied capable of degrading organic matter with a very high efficiency (up to 80%) and to remove nitrate nitrogen with equally high efficiency (up to 99%). Based on collected data, a multivariate statistical analysis was applied highlighting a correlation between several pollutants fed and performances of the process. This can be a useful tool for the manager of AWTPs for deciding the correct mixture of AW to feed to the biological reactor. The respirometric tests (AUR and NUR) confirmed results obtained by monitoring data analysis and helped to fully understand ammonia fate in the reactor. As far as nitrification is concerned, there is an increase in ammonium ions due to the hydrolysis of the organic substance that occurs in the reactor and, while, on the other, a stripping of the same ammonia nitrogen in the form of NH_3 as confirmed by the respirometric tests. Based on fluorescent in situ hybridization tests, no AOB, NOB, and anammox bacteria were identified in a 50 $^\circ\text{C}$ pure oxygen thermophilic biomass.

Author Contributions: Conceptualization: M.C.C. and G.B.; methodology: M.C.C., R.P., M.C.M. and M.B.; validation: M.C.C., M.B. and G.B.; formal analysis: S.B. and M.C.M.; investigation: R.P., S.B. and F.M.C.; resources: M.C.C., R.P. and G.B.; data curation: S.B. and F.M.C.; writing—original draft preparation: S.B., M.C.M. and A.A.; writing—review and editing: R.P., S.B. and M.C.M.; visualization: S.B., M.C.M., F.M.C. and A.A.; supervision: M.C.C. and G.B.; funding acquisition: M.C.C. All authors have read and agreed to the published version of the manuscript.

Funding: The authors thank Idroclean S.r.l. (Itelyum Group) for providing financial support to the research activities.

Data Availability Statement: All data generated or analysed during this study are included in this published article.

Acknowledgments: The authors thank Idroclean S.r.l. (Itelyum Group) for providing operational support to the research activities.

Conflicts of Interest: The authors declare no conflict of interest.

References

1. Kurniawan, T.A.; Chan, G.Y.S.; Lo, W.-H.; Babel, S. Physico–Chemical Treatment Techniques for Wastewater Laden with Heavy Metals. *Chem. Eng. J.* **2006**, *118*, 83–98. [[CrossRef](#)]
2. Kümmerer, K.; Al-Ahmad, A.; Mersch-Sundermann, V. Biodegradability of Some Antibiotics, Elimination of the Genotoxicity and Affection of Wastewater Bacteria in a Simple Test. *Chemosphere* **2000**, *40*, 701–710. [[CrossRef](#)]
3. Ren, S. Assessing Wastewater Toxicity to Activated Sludge: Recent Research and Developments. *Environ. Int.* **2004**, *30*, 1151–1164. [[CrossRef](#)] [[PubMed](#)]
4. Ahmed, M.B.; Zhou, J.L.; Ngo, H.H.; Guo, W.; Thomaidis, N.S.; Xu, J. Progress in the Biological and Chemical Treatment Technologies for Emerging Contaminant Removal from Wastewater: A Critical Review. *J. Hazard. Mater.* **2017**, *323*, 274–298. [[CrossRef](#)]
5. Rúa-Gómez, P.C.; Guedez, A.A.; Ania, C.O.; Püttmann, W. Upgrading of Wastewater Treatment Plants through the Use of Unconventional Treatment Technologies: Removal of Lidocaine, Tramadol, Venlafaxine and Their Metabolites. *Water* **2012**, *4*, 650–669. [[CrossRef](#)]
6. Ahmad, T.; Aadil, R.M.; Ahmed, H.; Rahman, U.; Soares, B.C.V.; Souza, S.L.Q.; Pimentel, T.C.; Scudino, H.; Guimarães, J.T.; Esmerino, E.A.; et al. Treatment and Utilization of Dairy Industrial Waste: A Review. *Trends Food Sci. Technol.* **2019**, *88*, 361–372. [[CrossRef](#)]
7. Ramos, C.; Suárez-Ojeda, M.E.; Carrera, J. Biodegradation of a High-Strength Wastewater Containing a Mixture of Ammonium, Aromatic Compounds and Salts with Simultaneous Nitritation in an Aerobic Granular Reactor. *Process Biochem.* **2016**, *51*, 399–407. [[CrossRef](#)]
8. Collivignarelli, M.C.; Abbà, A.; Bertanza, G. Treatment of High Strength Pharmaceutical Wastewaters in a Thermophilic Aerobic Membrane Reactor (TAMR). *Water Res.* **2014**, *63*, 190–198. [[CrossRef](#)]
9. Simstich, B.; Beimfohr, C.; Horn, H. Lab Scale Experiments Using a Submerged MBR under Thermophilic Aerobic Conditions for the Treatment of Paper Mill Deinking Wastewater. *Bioresour. Technol.* **2012**, *122*, 11–16. [[CrossRef](#)]
10. LaPara, T.M.; Nakatsu, C.H.; Pantea, L.; Alleman, J.E. Phylogenetic Analysis of Bacterial Communities in Mesophilic and Thermophilic Bioreactors Treating Pharmaceutical Wastewater. *Appl. Environ. Microbiol.* **2000**, *66*, 3951–3959. [[CrossRef](#)]
11. Collivignarelli, M.C.; Abbà, A.; Bertanza, G.; Setti, M.; Barbieri, G.; Frattarola, A. Integrating Novel (Thermophilic Aerobic Membrane Reactor-TAMR) and Conventional (Conventional Activated Sludge-CAS) Biological Processes for the Treatment of High Strength Aqueous Wastes. *Bioresour. Technol.* **2018**, *255*, 213–219. [[CrossRef](#)] [[PubMed](#)]
12. Collivignarelli, M.C.; Carnevale Miino, M.; Baldi, M.; Manzi, S.; Abbà, A.; Bertanza, G. Removal of Non-Ionic and Anionic Surfactants from Real Laundry Wastewater by Means of a Full-Scale Treatment System. *Process Saf. Environ. Prot.* **2019**, *132*, 105–115. [[CrossRef](#)]
13. Collivignarelli, M.C.; Carnevale Miino, M.; Caccamo, F.M.; Baldi, M.; Abbà, A. Performance of Full-Scale Thermophilic Membrane Bioreactor and Assessment of the Effect of the Aqueous Residue on Mesophilic Biological Activity. *Water* **2021**, *13*, 1754. [[CrossRef](#)]
14. Collivignarelli, M.C.; Abbà, A.; Frattarola, A.; Manenti, S.; Todeschini, S.; Bertanza, G.; Pedrazzani, R. Treatment of Aqueous Wastes by Means of Thermophilic Aerobic Membrane Reactor (TAMR) and Nanofiltration (NF): Process Auditing of a Full-Scale Plant. *Environ. Monit. Assess.* **2019**, *191*, 708. [[CrossRef](#)] [[PubMed](#)]
15. Collivignarelli, M.C.; Abbà, A.; Carnevale Miino, M.; Caccamo, F.M.; Argiolas, S.; Bellazzi, S.; Baldi, M.; Bertanza, G. Strong Minimization of Biological Sludge Production and Enhancement of Phosphorus Bioavailability with a Thermophilic Biological Fluidized Bed Reactor. *Process Saf. Environ. Prot.* **2021**, *155*, 262–276. [[CrossRef](#)]
16. Brock, T.D. Life at High Temperatures. *Science* **1985**, *230*, 132–138. [[CrossRef](#)]
17. Harrou, F.; Dairi, A.; Sun, Y.; Senouci, M. Statistical Monitoring of a Wastewater Treatment Plant: A Case Study. *J. Environ. Manage.* **2018**, *223*, 807–814. [[CrossRef](#)]
18. Aguado, D.; Rosen, C. Multivariate Statistical Monitoring of Continuous Wastewater Treatment Plants. *Eng. Appl. Artif. Intell.* **2008**, *21*, 1080–1091. [[CrossRef](#)]
19. Muszyński, A.; Tabernacka, A.; Miłobędzka, A. Long-Term Dynamics of the Microbial Community in a Full-Scale Wastewater Treatment Plant. *Int. Biodeterior. Biodegrad.* **2015**, *100*, 44–51. [[CrossRef](#)]
20. O'Brien, G.J.; Teather, E.W. A Dynamic Model for Predicting Effluent Concentrations of Organic Priority Pollutants from an Industrial Wastewater Treatment Plant. *Water Environ. Res.* **1995**, *67*, 935–942. [[CrossRef](#)]
21. Rice, E.W.; Baird, R.B.; Eaton, A.D. *APHA Standards Methods for the Examination of Water and Wastewater*, 22nd ed.; American Public Health Association: Washington, DC, USA, 2012.
22. Masotti, L. *Water Treatment. Techniques and Plants for the Treatment of Wastewater (In Italian)*; Calderini: Milano, Italy, 2011; ISBN 978-88-506-5202-0.

23. Rebekić, A.; Lončarić, Z.; Petrović, S.; Marić, S. Pearson's or spearman's correlation coefficient—Which one to use? *Poljoprivreda* **2015**, *21*, 47–54. [[CrossRef](#)]
24. Siwek, K.; Osowski, S. Data Mining Methods for Prediction of Air Pollution. *Int. J. Appl. Math. Comput. Sci.* **2016**, *26*, 467–478. [[CrossRef](#)]
25. Collivignarelli, M.C.; Abbà, A.; Bertanza, G.; Frattarola, A. The Upgrading of Conventional Activated Sludge Processes with Thermophilic Aerobic Membrane Reactor: Alternative Solutions for Sludge Reduction. *J. Environ. Manage.* **2020**, *264*, 110490. [[CrossRef](#)] [[PubMed](#)]
26. Philippsen, C.G.; Vilela, A.C.F.; Zen, L.D. Fluidized Bed Modeling Applied to the Analysis of Processes: Review and State of the Art. *J. Mater. Res. Technol.* **2015**, *4*, 208–216. [[CrossRef](#)]
27. Mikkelsen, L. Physico-Chemical Characteristics of Full Scale Sewage Sludges with Implications to Dewatering. *Water Res.* **2002**, *36*, 2451–2462. [[CrossRef](#)]
28. Cieślak, B.M.; Namieśnik, J.; Konieczka, P. Review of Sewage Sludge Management: Standards, Regulations and Analytical Methods. *J. Clean. Prod.* **2015**, *90*, 1–15. [[CrossRef](#)]
29. Carrera, J.; Vicent, T.; Lafuente, J. Effect of Influent COD/N Ratio on Biological Nitrogen Removal (BNR) from High-Strength Ammonium Industrial Wastewater. *Process Biochem.* **2004**, *39*, 2035–2041. [[CrossRef](#)]
30. de Winter, J.C.F.; Gosling, S.D.; Potter, J. Comparing the Pearson and Spearman Correlation Coefficients across Distributions and Sample Sizes: A Tutorial Using Simulations and Empirical Data. *Psychol. Methods* **2016**, *21*, 273–290. [[CrossRef](#)]
31. Insam, H.; de Bertoldi, M. *Chapter 3 Microbiology of the Composting Process*; Elsevier: Amsterdam, The Netherlands, 2007; pp. 25–48. ISSN 1478-7482. ISBN 9780080439600. [[CrossRef](#)]
32. Liwarska-Bizukojć, E.; Chojnacki, J.; Klink, M.; Olejnik, D. Effect of the Type of the External Carbon Source on Denitrification Kinetics of Wastewater. *Desalin. Water Treat.* **2018**, *101*, 143–150. [[CrossRef](#)]
33. Abbà, A.; Collivignarelli, M.C.; Manenti, S.; Pedrazzani, R.; Todeschini, S.; Bertanza, G. Rheology and Microbiology of Sludge from a Thermophilic Aerobic Membrane Reactor. *J. Chem.* **2017**, *2017*, 1–19. [[CrossRef](#)]